



Model: 07213A
Operator's Manual





READ THIS BOOK



This book has important information for the use and safe operation of this machine. Failure to read this book prior to operating or attempting any service or maintenance procedure to your American Sanders machine could result in injury to you or to other personnel; damage to the machine or to other property could occur as well. You must have training in the operation of this machine before using it. If your operator(s) cannot read this manual, have it explained fully before attempting to operate this machine.

All directions given in this book are as seen from the operator's position at the rear of the machine.



WARNING!

To reduce the risk of fire, electric shock, or injury:

- Do not use where explosive vapors, such as gas, solvents, alcohol, fuels, or combustible materials such as grain, wood dust, are present in the air. Keep the work area well ventilated.
- Dust produced from sanding wood or varnish could self ignite causing injury or damage. If this material has been picked up, empty it immediately after use in a metal container.
- Do not use to pick-up health endangering dust.
- Do not use unless machine is fully assembled. Do not modify the machine. Read all instructional labels on the machine. Replace damaged labels.
- Do not allow to be used as a toy. Close attention is necessary when used around children.
- Use extra care when cleaning on stairs.
- Connect to properly grounded outlet. See "grounding Instructions".
- Do not use unless all filtering elements are present. Clean filtering elements frequently.

SAVE THESE INSTRUCTIONS



WARNING!

The Products sold with this Manual contain or may contain chemicals that are known to certain governments (such as the State of California, as identified in its Proposition 65 Regulatory Warning Law) to cause cancer, birth defects or other reproductive harm. In certain locations (including the State of California) purchasers of these Products that place them in service at an employment job site or a publicly accessible space are required by regulation to make certain notices, warnings or disclosures regarding the chemicals that are or may be contained in the Products at or about such work sites. It is the purchaser's responsibility to know the content of, and to comply with, any laws and regulations relating to the use of these Products in such environments. The Manufacturer disclaims any responsibility to advise purchasers of any specific requirements that may be applicable to the use of the Products in such environments.

*****This product is intended for commercial use only*****

Contents

Symbols Used in the Manual.....	4
Purpose and Content of the Manual.....	4
Target Group.....	4
Storing the Use and Maintenance Manual.....	4
On Delivery of the Machine.....	5
Introductory Comment.....	5
Identification Data.....	5
Technical Description.....	5
Intended Use.....	5
Safety.....	5
Serial Number Plate.....	5
Technical Data.....	6
General Safety Regulations.....	7
Preparation of the Machine.....	9
Handling the Packed Machine.....	9
Unpacking the Machine.....	9
Transport Machine.....	9
Machine Components - Main.....	10
Machine Components - Tank Cover.....	10
Machine Components - Tank.....	10
Machine Safety.....	11
Preparing the Machine.....	11
Machine Operation.....	13
Post Operation.....	14
Maintenance.....	14
Maintenance Schedule.....	14
Removing & Cleaning the Dust Bag.....	15
Cleaning the Collection Tank.....	16
Cleaning the Accessories.....	17
Cleaning the Fabric Filter.....	18
Disposal.....	19
Troubleshooting.....	20
Parts Manual.....	21
Electrical Schematic.....	22
Filters.....	23
Vacuum Motor Assembly.....	24
Tank Assembly.....	26
Cover Assembly.....	28
Accessories.....	30
Warranty.....	31

The descriptions contained in this document are not binding. The company therefore reserves the right to make any modifications at any time to elements, details, or accessory supply, as considered necessary for reasons of improvement or manufacturing/commercial requirements. The reproduction, even partial, of the text and drawings contained in this document is prohibited by law.

American Sanders reserves the right to make any technical and/or supply modifications. The images are shown as a reference only, and are not binding as to the actual design and/or equipment.

Symbols Used in the Manual



Open book symbol:

Tells the operator to read the manual before using the appliance.



Open book symbol:

Tells the operator to read the manual before using the appliance.



Covered place symbol:

the operations preceded by this symbol must always be carried out in a dry, covered area.



Warning symbol:

Carefully read the sections marked with this symbol and observe the indications, for the safety of the operator and the appliance.



Disposal symbol:

carefully read the sections marked with this symbol for disposing of the appliance.



Protective gloves symbol:

Always wear protective gloves, to avoid the risk of serious injury to your hands caused by sharp objects.



Protective gloves symbol:

Always wear protective gloves, to avoid the risk of serious injury to your hands caused by chemical agents.



Information symbol:

Indicates additional information for the operator, to improve the use of the device.

Purpose & Content of the Manual

The aim of this manual is to provide customers with all the information needed to use the appliance in the safest, most appropriate and most autonomous way. It includes information concerning technical aspects, safety, operation, appliance downtime, maintenance, spare parts and scrapping. Operators and qualified technicians must read the instructions in this manual carefully before carrying out any operation on the appliance. If in doubt about the correct interpretation of instructions, contact your nearest Customer Service Center to obtain the necessary clarifications.

Target Group

This manual is aimed at operators and qualified technicians responsible for appliance maintenance. Operators must not perform operations that should be carried out by qualified technicians. American Sanders cannot be held liable for damages resulting from failure to comply with this prohibition.

Manual Storage

The Use and Maintenance Manual must be stored, protected from liquids and anything else that could compromise its legibility.

Machine Delivery

When the machine is delivered to the customer, an immediate check must be performed to ensure all the material mentioned in the shipping documents has been received, in addition to verifying that the equipment has not been damaged during transportation. If this is the case, the carrier must ascertain the extent of the damage at once, informing our customer service office. It is only by prompt action of this type that the missing material can be obtained, and compensation for damage successfully claimed.

Introduction

Any type of equipment can only work properly and effectively if used correctly and kept in full working order by performing the maintenance operations described in the attached documentation. You should therefore read this instruction manual carefully, consulting it again if issues arise while using the machine. If necessary, remember that our assistance service (organised in collaboration with our dealers) is always available for advice or direct intervention.

Identification Data

For technical assistance or to request replacement parts, always give the model, the version and serial number written on the serial number plate.

Technical Description

The AVac26 is a vacuum cleaner which uses the vacuum created inside the collection tank by the fan (enabled by the electric motor) to pick up dust and dry solid elements at ambient temperature, using the accessories in contact with the floor and the furnishings. The vacuum hose conveys inside the collection tank the air with dust and solid residues that are retained and collected using the collection bag and the filter. The appliance must only be used for this purpose.

Intended Use

This appliance is designed and built to be used by a qualified operator to clean (by vacuuming solid, dry elements) smooth, compact flooring in the commercial, residential and industrial sectors, in proven safety conditions.



The appliance is only suitable for use in indoor - or at least covered - areas. The appliance is not suitable for use in the rain, or under jets of water. IT IS FORBIDDEN to use the appliance for picking up dangerous dusts or inflammable liquids in places with an explosive atmosphere. In addition, it is not suitable as a means of transport for people or objects.

Safety

Operator cooperation is paramount for accident prevention. No accident prevention program can be effective without the full co-operation of the operator who is directly responsible for machine operation. The majority of occupational accidents that happen both in the workplace or whilst moving are caused by failure to respect the most basic safety rules. An attentive, careful operator is most effective guarantee against accidents and is fundamental in order to implement any prevention program.

Serial Number Plate

The serial number plate is located at the rear of the vacuum cleaner, and indicates the general characteristics of the appliance, in particular the appliance's serial number. The serial number is a very important piece of information and should always be provided together with any request for assistance or to purchase spare parts.

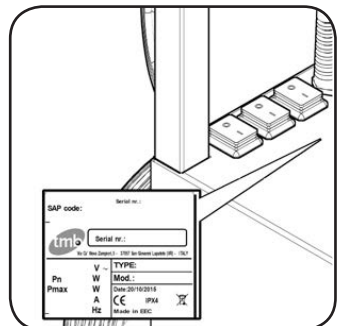

Machine Specifications

Technical Data	Unit of Measure	AVac 26
Power Supply Voltage	Volts (V)	115 V
Total Power (Nominal)	Watts (W)	2400 W
Frequency	Hertz (Hz)	50-60 Hz
Number of Vacuum Motors	Number	3
Vacuum Motor	Qty (V / W / Hz)	3 (120 / 800 / 60)
Type of Vacuum	Stage(s) / Discharge	2 / Tangential
Maximum Vacuum	Inches of Water (inH ² O) Kilopascal (kPa)	72 inH ² O 17.9 kPa
Maximum Air Flow Rate	Cubic Feet per Minute (CFM) Cubic Meters per Minute (CMM)	255 CFM 7.22 CMM
Collection Capacity	Gallon (gal) / Liter (L)	26.4 gal / 100 L
Filtration Capacity (Class L)	in ² / cm ²	5500 in ² / 35500 cm ²
Tank Material	N/A	Coated Steel
Cord Length	Feet (ft) / Meters (m)	50 ft / 15 m
Dry (Empty) Weight	Pounds (lbs) Kilograms (kg)	121.3 lbs 55 kg
Dimensions (Length X Width X Height)	Inches (in) Centimeters (cm)	21.3 in X 26.8 in X 39.7 in 54 cm X 68 cm X 109 cm
Hose Diameter	Inches (in) Millimeters (mm)	2.00 in 50 mm
Protection Rating	IP	X4
Sound Level (ISO 11201)	dB(A)	80

GENERAL SAFETY REGULATIONS

The regulations below must be carefully followed in order to avoid harm to the operator and damage to the appliance.

CAUTION:

- **Carefully read the warnings contained in this booklet and take care of it for further consultations.**
- Since the packaging elements (plastic bags, staples, etc.) are a source of danger they should not be left within the reach of children, disabled persons, etc.
- This appliance should only be used for the purpose for which it was constructed, namely: cleaning inert surfaces, the aspiration of solid non-flammable and non-explosive substances. Any other use is considered incorrect and hence dangerous.
- When the appliance is operating do not bring it close to delicate organs like ears, mouth, eyes, etc.
- This appliance should not be used by people (including children) with physical, sensory or mental disabilities, or by people with little experience or know-how, unless they have been controlled and instructed in the use of the appliance by people responsible for their safety. Children must be supervised to ensure they do not play with the appliance.
- Carefully read the labels on the appliance. Do not cover them for any reason and replace them immediately if they become damaged.
- The appliance must be only used by authorised, trained personnel.
- The appliance is not suitable for cleaning rough or uneven floors. Do not use the appliance on slopes.
- It is necessary to make sure that the power supply cable or the extension cable do not suffer any damage caused by the vehicle wheels when moving, by crushing, tearing or the like. Protect the cable from heat, oil and sharp edges. Regularly check the power cable for any damage such as the formation of cracks, or ageing. If you notice any damage, the cable must be replaced before using the machine.
- In the event of danger, immediately remove the plug from the electrical outlet or socket.
- For maintenance work, switch off the appliance using the main switches and remove the power cable plug from the electrical outlet.
- When using the appliance, pay attention to other people and especially to children.
- Use only the accessories recommended by American Sanders Authorized Distributors. The use of other accessories could compromise the safety of the appliance.
- When the appliance is not being used, it should not be left connected to the electrical outlet and/or power supply.
- Before doing any maintenance work on the appliance pull out the plug from the electrical outlet and/or power supply.
- Do not immerse the appliance in water, do not use solvents.
- For scrapping, follow the regulations in force in the country.
- Do not use the appliance with the power cable twisted around any part of the appliance.
- Before connecting the appliance to the electricity socket, make sure the electrical information on the serial number plate corresponds to that of the electrical supply. The appliance must only be powered with a voltage equal to that shown on the serial number plate.
- The manufacturer cannot be held liable for any damage to persons, animal or objects deriving from improper and unreasonable use, and in any event not complying with the instructions mentioned above.

GROUNDING INSTRUCTIONS:

This appliance must be grounded. If it should malfunction or breakdown, grounding provides a path of least resistance for electric current to reduce the risk of electric shock. This appliance is equipped with a cord that has an equipment-grounding conductor and grounding plug. The plug must be inserted into an appropriate outlet that is properly installed and grounded in accordance with all local codes and ordinances.

WARNING! Improper connection of the equipment-grounding conductor can result in a risk of electric shock. Check with a qualified electrician or service person if you are in the doubt as to whether the outlet is properly grounded. Do not modify the plug provided with the appliance-if it will not fit the outlet, have a proper outlet installed by a qualified electrician.

Make sure that the appliance is connected to an outlet having the same configuration as the plug. No adapter should be used with this appliance. If the appliance must be reconnected for use on a different type of electric circuit, the reconnection should be made by a qualified service personnel.

WARNING:

- This appliance is suitable for dry use only. Never vacuum any liquid substance into the collection tank.
- The appliance is not suitable for use by children and persons with reduced physical, mental and sensory capabilities, or people who lack the required experience and knowledge.
- The appliance must not be used or kept outdoors, in damp conditions or directly exposed to rain.
- The storage temperature must be between -13°F and 131°F (-25°C and +55°C).
- Conditions of use: room temperature between 32°F and 104°F (0°C and 40°C), with relative humidity between 30% and 95%.
- The power supply cable outlet must have an earth connection in compliance with the regulatory standards.
- The appliance does not cause harmful vibrations.
- Never vacuum gas, liquids or explosive or inflammable powders, nor non-diluted acids and solvents! These include gasoline, paint thinners and fuel oil (which, when mixed with the vacuum air, can form explosive vapours or mixtures), and also non-diluted acids and solvents, acetones, aluminium and magnesium powders. These substances may also corrode the materials used to construct the appliance.
- The appliance must never be used in environments with a potentially explosive atmosphere.
- Do not place any liquid containers on the appliance.
- In the event of a fire, use a powder extinguisher. Do not use water.
- Do not knock against shelving or scaffolding, where there is a danger of falling objects. The operator using the appliance should always be equipped with suitable safety devices (gloves, shoes, helmet, goggles, etc.).
- If the appliance does not work properly, ask for intervention of the authorized technical assistance center.
- If you need to replace any components, request the ORIGINAL spare parts from an Authorized dealer and/or Retailer.
- Restore all electrical connections after any maintenance interventions.
- Before using the appliance, check that all the hatches and covers are positioned as shown in this Use and Maintenance Manual.
- Do not remove the guards that can only be removed with the aid of tools, except for maintenance work (see the relevant paragraphs).
- Do not wash the appliance with direct water jets or with pressurised water, nor with corrosive substances.
- Have the appliance checked by an authorised technical assistance center every year.
- When disposing of consumable materials, observe the laws and regulations in force.
- Dust produced from sanding wood or varnish could self ignite causing injury or damage. If this material has been picked up, empty it immediately after use into a metal container. Never leave sanding dust of any amount supervised.
- When, after years of valuable work, your appliance needs to be finally decommissioned, dispose of the materials contained within it appropriately, bearing in mind that the appliance is made of fully recyclable materials.

Handling the Packaged Machine

Since the packaging elements (plastic bags, staples, etc.) are a potential source of danger, they should not be left within the reach of children, disabled persons, etc.

The gross weight of the appliance, including packaging, is 144 lbs (65 Kg).



WARNING: Move the packaged product in accordance with legal legislation requirements regarding accident prevention, the size and the mass of the packaging itself.

A	43.7 in (1110 mm)
B	23.1 in (586 mm)
C	25.4 in (646 mm)

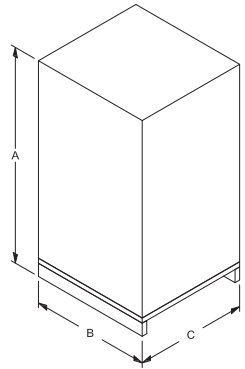

Unpacking the Machine

The procedure for removing the device from its packaging is the following:

1. Place the lower part of the outer packaging in contact with the floor.



WARNING: Use the pictograms printed on the box as reference.

2. Remove the outer package.



WARNING: these operations must be carried out using protective gloves to avoid any possible contact with the edges or tips of metal objects.

3. Using a chute, slide the machine from the pallet.

Transport Machine

To transport the machine, proceed as follows:

1. Take all necessary steps to ensure that the device is in a safe condition (see "MACHINE SAFETY").



WARNING: Users are advised to always wear protective gloves, to avoid the risk of serious injury to hands.

2. Make sure that the collection tank is empty, otherwise empty it (read the paragraph "CHECKING AND CLEANING THE COLLECTION BAG").



WARNING: for transportation without a pallet, secure the device according to the directives in force in the country of use so that it does not slide or tip over.

Machine Components - Main

The basic components of the machine are as follows:

1. Collection Tank
2. Tank Cover
3. Filter / Collection Bag

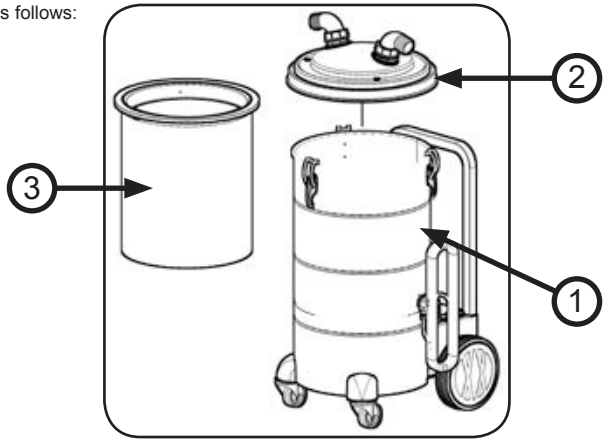

Machine Components - Tank Cover

The basic components of the tank cover are as follows:

1. Tank Lid
2. Vacuum Port
3. Port Plug

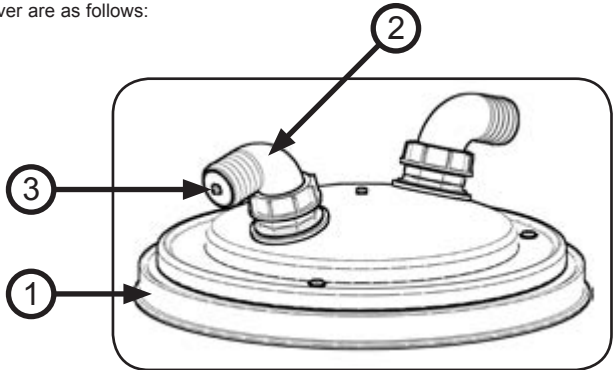

Machine Components - Tank

The basic components of the tank are as follows:

1. Collection Tank
2. Swivel Casters
3. Rear Wheels
4. Motor Switches
5. Exhaust Filter
6. Handle
7. Cover Latch

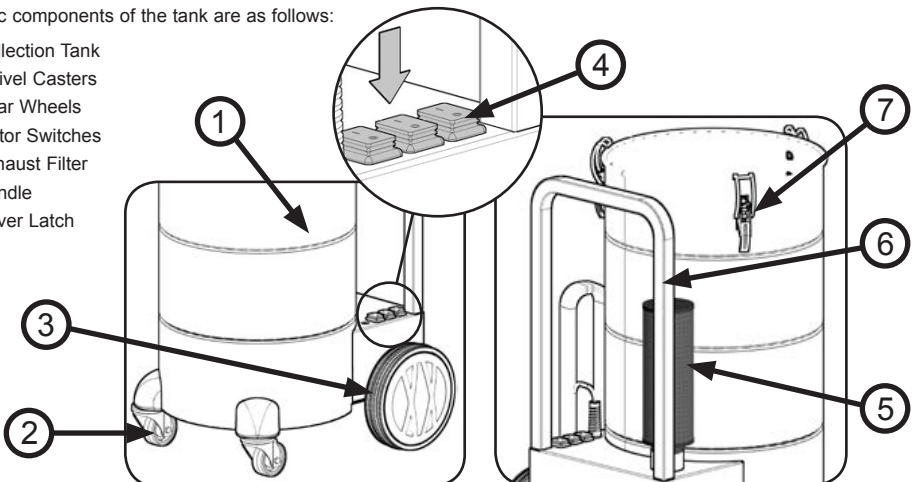

Machine Safety

The stages for making the appliance safe, thereby making it possible to carry out operations safely, are as follows:

1. Make sure that the main switch (1) is in the rest position, if not, disable it by pushing the switch to "0" (**Fig. 1**).
2. Make sure that the plug (2) on the power cable (3) has been taken out of the electrical outlet and/or power supply socket (4), and if not, disconnect it (**Fig. 2**).
3. Wind the cable around the control handlebar.



WARNING: Users are advised to always wear protective gloves, to avoid the risk of serious injury to hands.



WARNING: To prevent any damage to the electrical outlet and/or power supply socket, pull out the plug (2) from the electrical outlet and/or power supply socket (4) by pulling the plug (2) directly instead of the power cable (3).

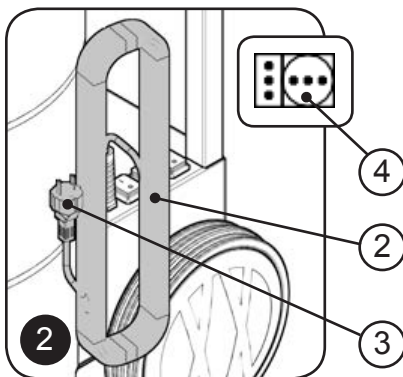
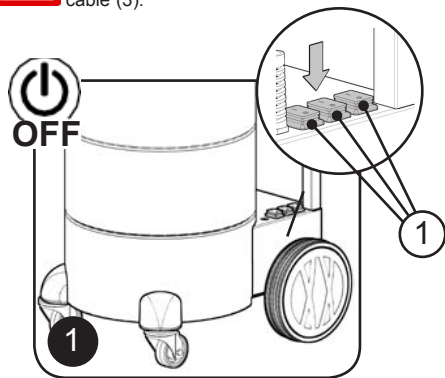

Preparing the Machine

Before beginning to work, it is necessary to:

1. Before using, the appliance must be in order and safe to use with the work equipment, especially the power cable and the extension cable. If everything is not in order, the appliance must not be used.
2. Take all necessary steps to ensure that the device is in a safe condition (see "MACHINE SAFETY").



WARNING: Users are advised to always wear protective gloves, to avoid the risk of serious injury to hands.

3. Free the cover from the collection tank by releasing its hooks (1) on the side of the collection tank (**Fig. 1**).
4. Remove the cover (2) from the collection tank (**Fig. 2**).

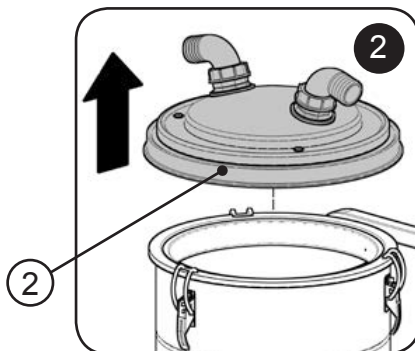
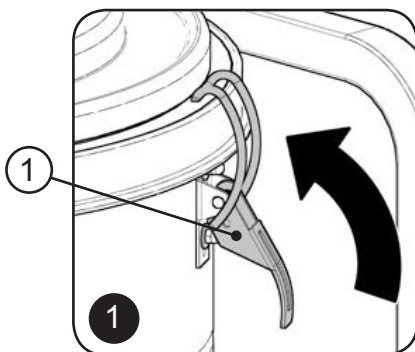

5. Put the cover delicately on the floor.

- Check that the fabric vacuum filter (3) is inside the tank, if not put it in (*Fig. 3*).
- Insert the collection bag (4) inside the collection tank (*Fig. 4*), being careful to position it correctly inside the filter.

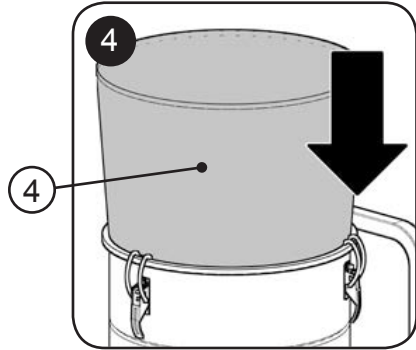
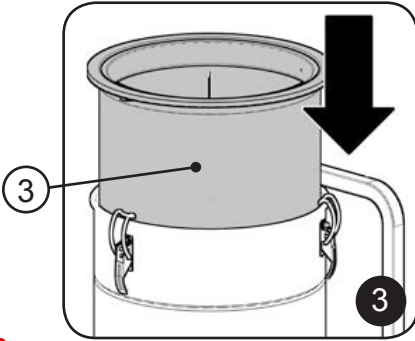

WARNING: To fix the collection bag fold the hem around the inlet mouth of the collection tank.

- Put the cover (2) on the collection tank (*Fig. 5*).
- Fix the cover to the collection tank by using its hooks (1) on the side of the collection tank (*Fig. 6*).

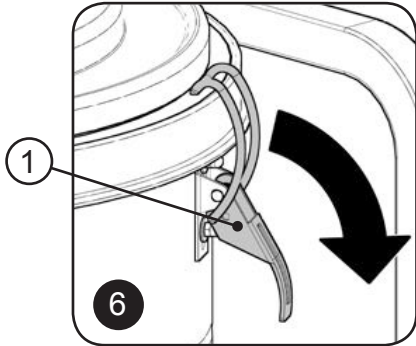
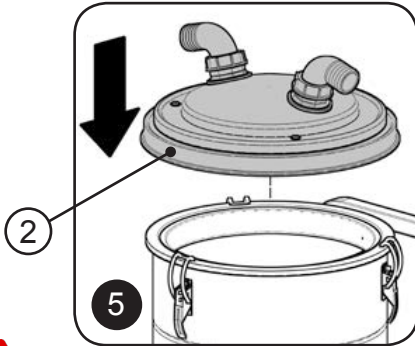

WARNING: The collection bag-filter should only be used for collecting solid waste.



WARNING: When using the collection bag, do not vacuum waste that could cut it, burning embers that could set it on fire, or acid solutions that could dissolve it

- Make sure that the cap closing the vacuum nozzle (5) has been correctly inserted (*Fig. 7*)
- Insert the vacuum hose (6) into the vacuum nozzle (7) in the cover (*Fig. 8*)

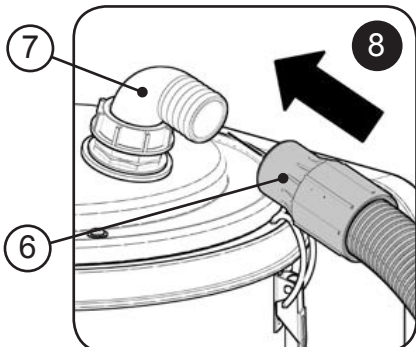
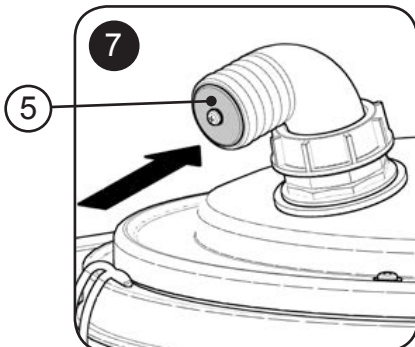

12. Select the most suitable accessory for the work to be carried out.
13. Insert the selected accessory into the vacuum hose.



WARNING: Never use the appliance without the filters supplied with the machine.

Machine Operation

To start using the machine, do as follows:

1. Carry out all the checks in the section "PREPARING TO WORK".
2. Insert the plug (1) of the power supply cable (2) in the electrical outlet and/or power supply socket (3) (**Fig. 1**).
3. Switch on the machine by positioning one of the three switches (4) to the work position "I" (**Fig. 2**).

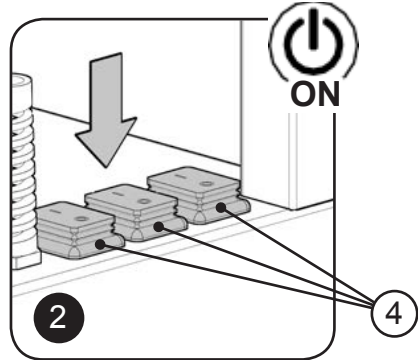
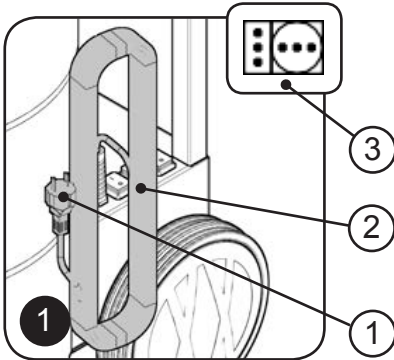

NOTICE: To double or triple the vacuum performance progressively activate the other two switches.

4. Proceed with the vacuuming.



NOTICE: If, when working, the intensity of the vacuum should drop, read section "CONTROL AND OPERATION".

Post Operation

At the end of the work, and before carrying out any type of maintenance, perform the following operations:

1. Do what is required to make sure the machine is in a safe condition (see "**MACHINE SAFETY**").
2. Take the appliance to the designated place for emptying the collection tank.



CAUTION: The place designated for this operation must comply with current environmental protection regulations

3. Empty the collection tank (see the section "**REMOVING & CLEANING THE REUSABLE / DISPOSABLE DUST BAG**").
4. Remove any accessory attached to the hose or machine and clean it with a damp cloth.



NOTICE: When it is completely dry insert it into the accessories support on the rear of the collection tank (optional accessory).

5. Remove any extension or wand from the end of the hose and clean it under running water.



NOTICE: When it is completely dry insert it into the accessories support on the rear of the collection tank (Optional: **Accessory Bag - TMB416986**).

6. Remove the vacuum hose (1) (**Fig. 1**) from the vacuum nozzle (2) in the cover of the collection tank, clean it under running water.



NOTICE: Store in the collection tank.



CAUTION: Store the appliance in an enclosed place, on a flat surface; near the appliance there must be no objects that could either damage it, or be damaged through contact with it.



WARNING: Dust produced from sanding wood or varnish could self ignite causing injury or damage. If this material has been picked up, empty it immediately after use into a metal container. Never leave sanding dust of any amount unsupervised.

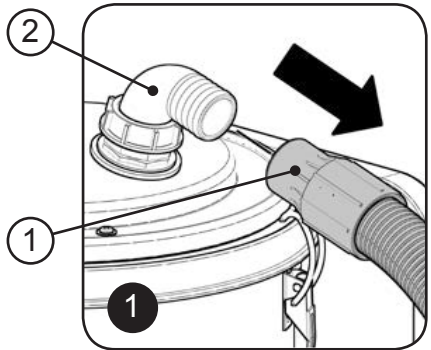

MAINTENANCE

Maintenance Schedule

Type of Maintenance	At the End of the Work	Daily	Weekly	Before a Long Period of Inactivity	Transport
Inspect and clean the collection bag	X		X	X	X
Inspect and clean the collection tank	X	X		X	X
Inspect and clean the vacuum accessories tools	X			X	
Inspect and clean the fabric filter		X		X	
Inspect and clean the sound insulation				X	
Inspect and clean the exhaust filter		X			

Removing & Cleaning the Reusable / Disposable Dust Bag

To empty the collection bag, proceed as follows:

1. Take all necessary steps to ensure that the device is in a safe condition (see "MACHINE SAFETY").



WARNING: Users are advised to always wear protective gloves, to avoid the risk of serious injury to hands.

2. Free the cover from the collection tank by releasing its hooks (1) on the side of the collection tank (**Fig. 1**).
3. Remove the cover (2) from the collection tank (**Fig. 2**).

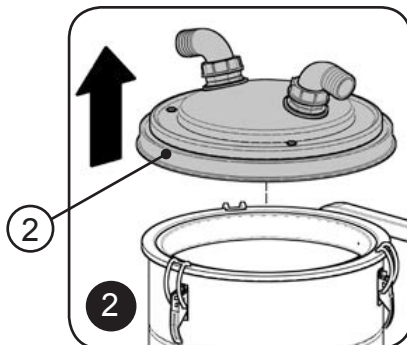
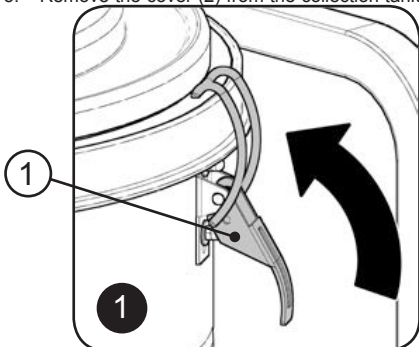

4. Put the cover delicately on the floor.
5. Fix the fabric filter to the collection tank by using its hooks (1) on the side of the collection tank (**Fig. 3**).
6. Remove the collection bag (3) from inside the appliance (**Fig. 4**).

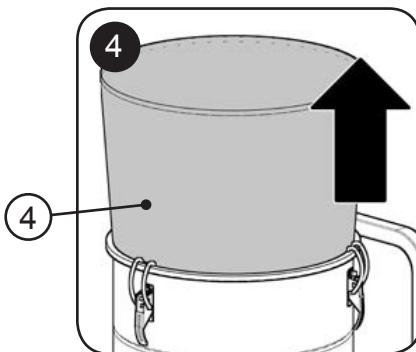
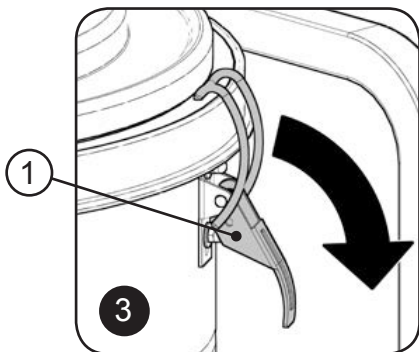

7. Take it to a suitable place and empty it.



CAUTION: the place designated for this operation must comply with current environmental protection regulations.

8. Vacuum the bag with a vacuum cleaner.
9. Clean the collection bag with an air jet from a distance of more than 20cm.
10. Inspect the reusable/disposable bag for any damage, holes or tears. If damaged, discard and replace.
11. To refit the collection bag carry out the operations in the reverse order.

Cleaning the Collection Tank

Properly cleaning the collection tank improves the appliance's efficiency. To clean the collection tank, proceed as follows:

1. Take all necessary steps to ensure that the device is in a safe condition (see "MACHINE SAFETY").



WARNING: Users are advised to always wear protective gloves, to avoid the risk of serious injury to hands.

2. Free the cover from the collection tank by releasing its hooks (1) on the side of the collection tank (**Fig. 1**).
3. Remove the cover (2) from the collection tank (**Fig. 2**).

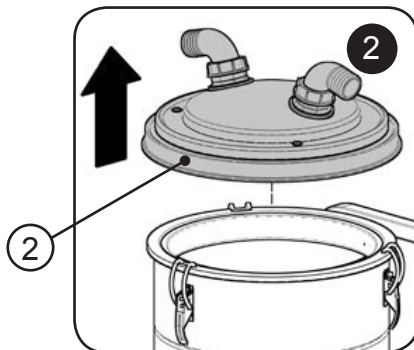
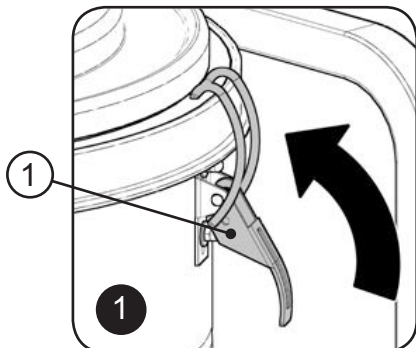

4. Put the cover delicately on the floor.
5. Remove the collection bag (3) from inside the appliance (**Fig. 3**).
6. Remove the fabric filter (4) from inside the appliance (**Fig. 4**).

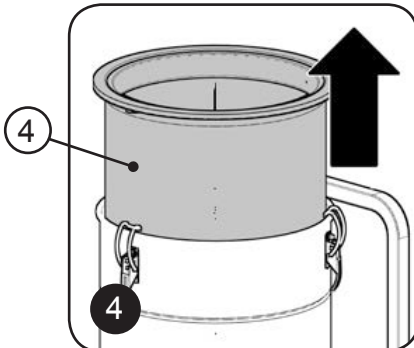
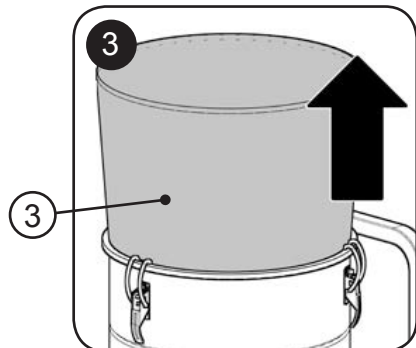

7. Take it to a suitable place for cleaning.



CAUTION: The place designated for this operation must comply with current environmental protection regulations.

8. Clean the inside of the collection tank with a cloth.
9. Clean the inside of the collection tank with a damp cloth.
10. To refit the collection bag carry out the operations in the reverse order. **WARNING:** To reduce the risk of fire, electric shock, or injury.



WARNING: Dust produced from sanding wood or varnish could self ignite causing injury or damage. If this material has been picked up, empty it immediately after use in a metal container.

Cleaning the Accessories

Properly cleaning the vacuum accessories improves the appliance's efficiency. Proceed as follows to clean the vacuum accessories:

1. Do what is required to make sure the machine is in a safe condition (see "MACHINE SAFETY").
2. Take the appliance to the designated place for emptying the collection tank.



CAUTION: The place designated for this operation must comply with current environmental protection regulations.

3. Remove the accessory from the extension, clean it with a damp cloth.



NOTICE: When it is completely dry insert it into the accessories support on the rear of the collection tank (Optional: **Accessory Bag - TMB416986**).

4. Remove the female part of the extension from the male part, clean it under running water.



NOTICE: When it is completely dry insert it into the accessories support on the rear of the collection tank (Optional: **Accessory Bag - TMB416986**).

5. Remove the vacuum hose (1) (**Fig. 1**) from the vacuum nozzle (2) in the cover of the collection tank, clean it under running water.



NOTICE: When it is completely dry insert it into the collection tank.

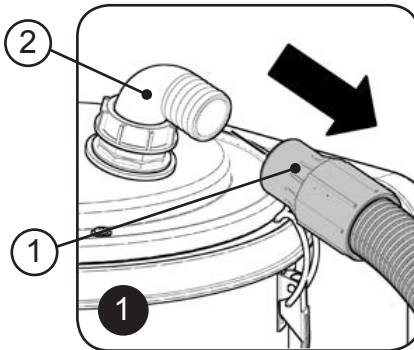

Cleaning the Polyester Fabric Filter

Properly cleaning the fabric filter improves the appliance's efficiency. To clean the fabric filter, proceed as follows:

1. Take all necessary steps to ensure that the device is in a safe condition (see "MACHINE SAFETY").



WARNING: Users are advised to always wear protective gloves, to avoid the risk of serious injury to hands.

2. Free the cover from the collection tank by releasing its hooks (1) on the side of the collection tank (**Fig. 1**).
3. Remove the cover (2) from the collection tank (**Fig. 2**).

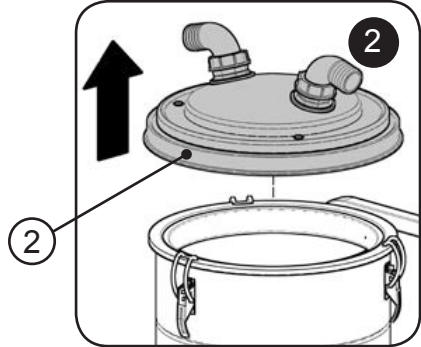
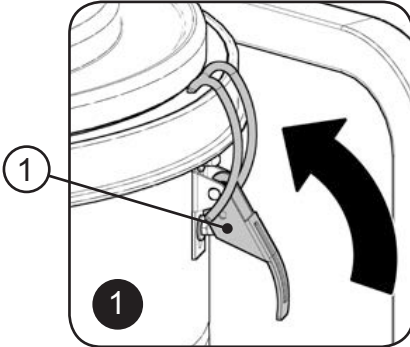

4. Put the cover delicately on the floor.
5. Remove the collection bag (3) from inside the appliance (**Fig. 3**).
6. Remove the fabric filter (4) from inside the appliance (**Fig. 4**).

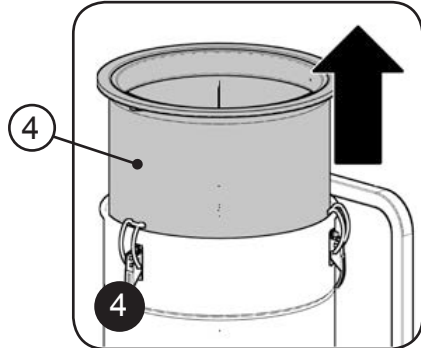
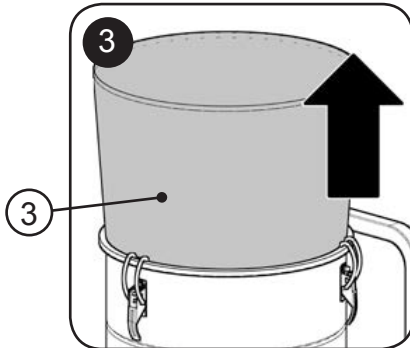

7. Take it to a suitable place for cleaning.



CAUTION: The place designated for this operation must comply with current environmental protection regulations.

8. Vacuum the fabric filter with another vacuum cleaner.
9. Clean the fabric filter with an air jet from a distance of more than 8.5 inches (20cm).
10. To refit the fabric filter carry out the operations in the reverse order.

DISPOSAL

To dispose of the appliance, take it to a demolition center or an authorised collection center.

Before scrapping the appliance, it is necessary to remove and separate out the following materials, then send them to the appropriate collection centers in accordance with applicable environmental hygiene regulations:

- Electric and electronic parts*
- Plastic parts
- Metallic parts

(* In particular, contact your distributor when scrapping electric and electronic parts.



TROUBLESHOOTING

This chapter lists the most common problems linked with the use of the appliance. If you are unable to resolve the problems with the information given here, please contact your nearest assistance center.

PROBLEM	POSSIBLE CAUSE	SOLUTION
The Machine Will Not Turn On	The main switch is in the off position.	Turn on the main switch.
	The power cable extension is not connected to the machine.	Connect the power cable plug to the main socket.
	The appliance's electronic specifications do not match the mains supply specifications.	Check that the technical information on the serial number plate. correspond to the mains supply information.
	The power cable is damaged.	If the power cable is damaged replace it, immediately contact an authorized the technical services of an American Sander distributor.
Dust Coming Out During Operation	The vacuum hose is not properly connected to the vacuum nozzle.	Connect the vacuum hose to the nozzle on the collection tank.
	The vacuum hose is not properly connected to the accessory in contact with the floor.	Connect the vacuum hose to the accessory that is being used to do the vacuuming.
	The collection tank cover has not been properly positioned.	Remove the collection tank cover and position the collection bag correctly.
	The collection bag has not been positioned correctly.	Remove the cover of the collection tank and empty the collection bag or else change it (see the paragraph " <u>REMOVING & CLEANING THE REUSABLE / DISPOSABLE DUST BAG</u> ").
	The collection bag is full or was torn.	Remove the collection tank cover, remove the collection bag and position the fabric filter correctly.
	The fabric filter is not correctly positioned.	Remove the collection tank cover, remove the collection bag and clean or replace the fabric filter (read the paragraph " <u>CLEANING THE POLYESTER FABRIC FILTER</u> ").
	The fabric filter is clogged or has torn.	Check that there is nothing obstructing the vacuum hose, if there is, remove it.
The Machine Is Not Collecting Dust	The vacuum hose is blocked.	Check that there is nothing obstructing the vacuum hose, if there is, remove it.
	The vacuum chamber of the accessory in contact with the floor is blocked.	Check that there is nothing obstructing the vacuum chamber of the accessory being used, if there is, remove it.
	The cap of the vacuum nozzle has not been closed properly.	Insert the cap into the vacuum nozzle correctly.

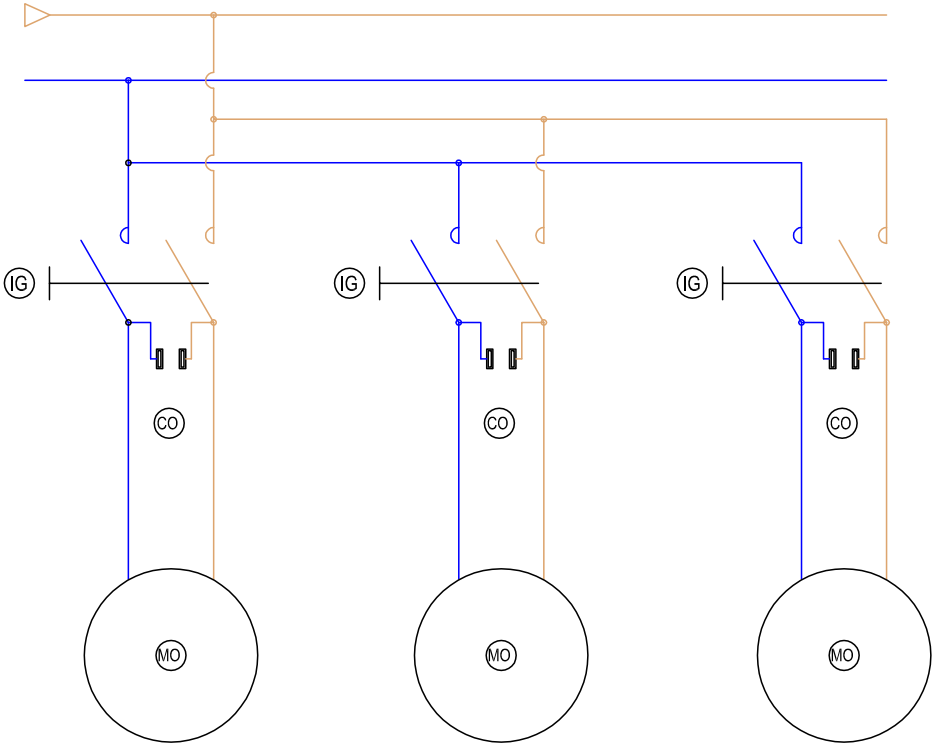

IG - Double Pole Switch
CO - Capacitor
MO - Vacuum Motor

Filters

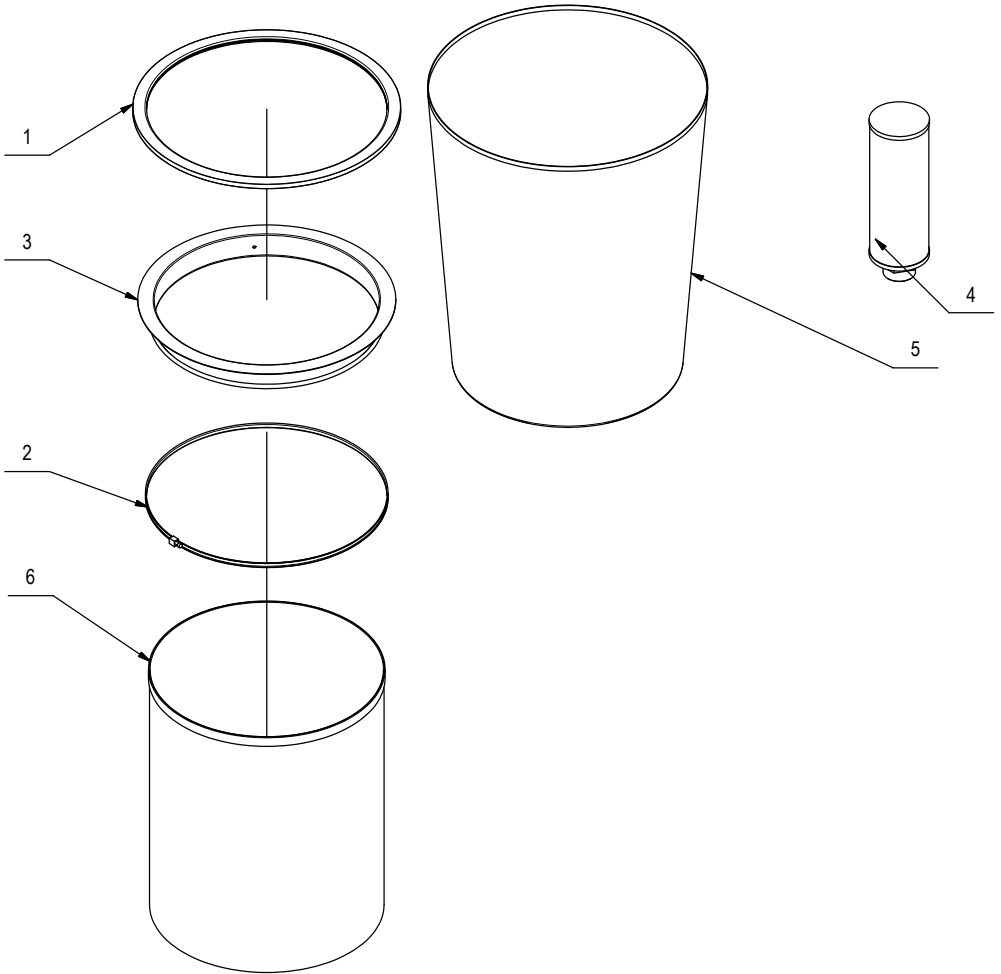

<u>Item</u>	<u>Ref. No.</u>	<u>Description</u>	<u>Qty</u>
1	TMB401051	GASKET, FILTER	1
2	TMB401053	CLAMP, BAND, FILTER	1
3	TMB416896	RING, RETAINING, FILTER	1
4	TMB441751	FILTER, EXHAUST, VAC	1
5	TMB225163	FILTER, REUSABLE, DISPOSABLE	1
6	TMB442055	FILTER, BAG, POLYESTER	1

Vacuum Motor Assembly

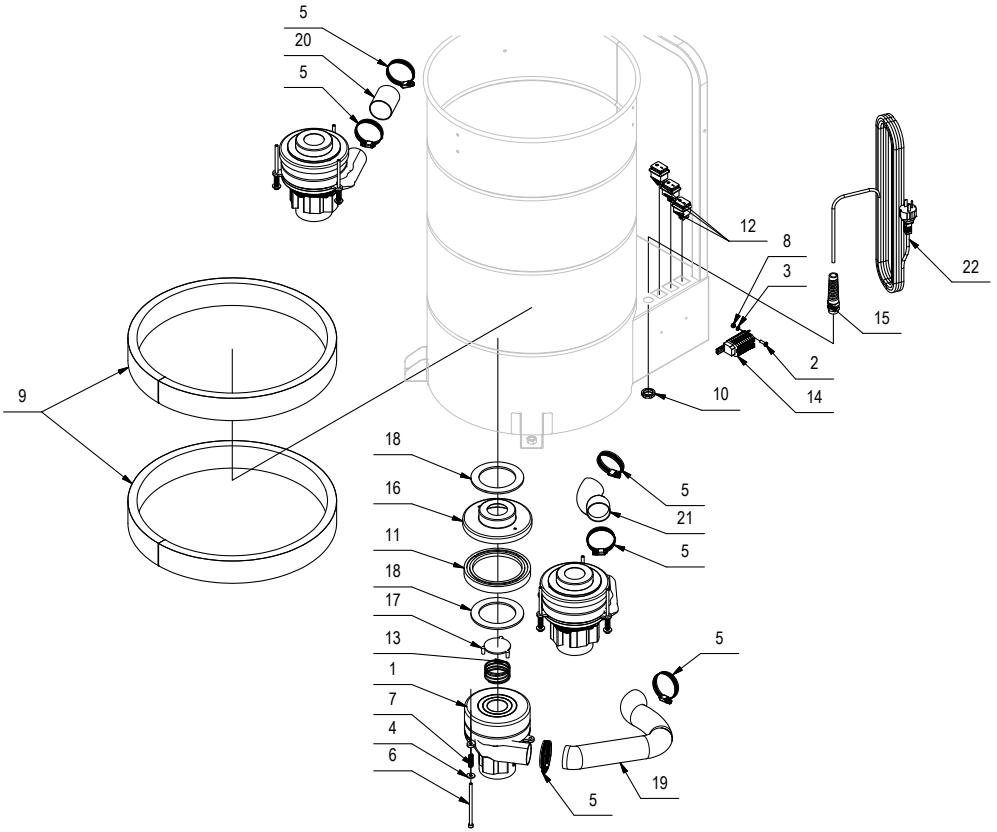

Vacuum Motor Assembly (continued)

<u>Item</u>	<u>Ref. No.</u>	<u>Description</u>	<u>Qty</u>
1	TMB442058	MOTOR, VAC, 120V, 800W	3
2	TMB408854	SCREW, M5 X 16MM	2
3	TMB409150	WASHER, M5 X 11MM X 1MM	2
4	TMB409160	WASHER, M6 X 18MM X 1.5MM	10
5	TMB410287	CLAMP, 40-60MM	6
6	TMB416696	SCREW, M6 X 110MM	9
7	TMB416725	SPRING, COMPRESSION	9
8	TMB416781	NUT, LOCK, M5	2
9	TMB417489	INSULATION, SOUND	2
10	TMB417523	NUT, RELIEF, CABLE	1
11	TMB417564	SEAL, MOTOR, VAC	3
12	TMB417622	SWITCH, DBL POLE	3
13	TMB417787	SPRING, VALVE	3
14	TMB417788	BLOCK, TERMINAL	1
15	TMB417826	RELIEF, STRAIN, CABLE	1
16	TMB417893	PORT, VALVE, VACUUM	3
17	TMB418253	VALVE, MOTOR, VAC	3
18	TMB421868	SEAL, PORT, VALVE	6
19	TMB422492	TUBING, 50MM	1
20	TMB422492	TUBING, 50MM	1
21	TMB422492	TUBING, 50MM	1
22	TMB442332	CORD, POWER, 14/3	1

Tank Assembly

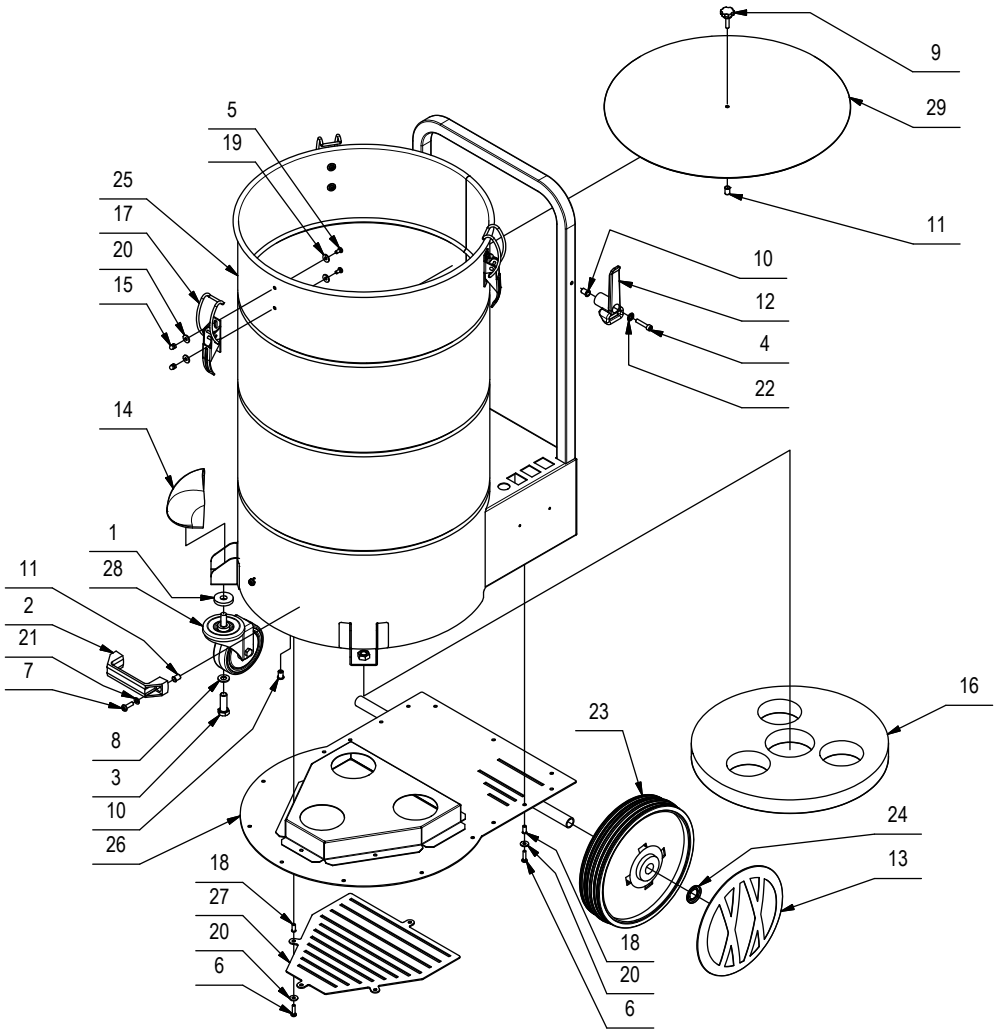

Tank Assembly (continued)

<u>Item</u>	<u>Ref. No.</u>	<u>Description</u>	<u>Qty</u>
1	TMB206357	WASHER, 12.5MM X 35MM X 6MM	2
2	TMB225164	HANDLE, BLACK	1
3	TMB408746	SCREW, M12 X 35MM	2
4	TMB408798	SCREW, M6 X 30MM	1
5	TMB408848	SCREW, M5 X 10MM	6
6	TMB408855	SCREW, M5 X 20MM	20
7	TMB408862	SCREW, M6 X 20MM	2
8	TMB409191	WASHER, M10 X 21MM X 2MM	2
9	TMB410227	KNOB, w/ PIN, M6 X 25MM	1
10	TMB410542	INSERT, M6 X 14MM	10
11	TMB410545	INSERT, M6 X 15MM	3
12	TMB416543	WRAP, CORD	1
13	TMB417186	COVER, WHEEL, BLACK	2
14	TMB417215	COVER, BOLT, WHEEL	2
15	TMB417262	NUT, M5	6
16	TMB417486	INSULATION, SOUND	1
17	TMB417505	LATCH, CLOSURE	3
18	TMB417609	INSERT, M5	20
19	TMB417986	WASHER, M5 X 15MM	6
20	TMB417987	WASHER, M5 X 15MM	26
21	TMB417993	WASHER, M6 X 12MM	2
22	TMB417998	WASHER, M8 X 17MM	1
23	TMB418013	WHEEL, BLACK, D250	2
24	TMB418140	LOCK, RETAINING, 20MM	2
25	TMB442029	TANK, COLLECTION	1
26	TMB442051	FRAME, VACUUM	1
27	TMB442052	GRILLE, EXHAUST, FILTER	1
28	TMB442309	CASTER, SWIVEL	2
29	TMB442311	SCREEN, VACUUM	1

Cover Assembly

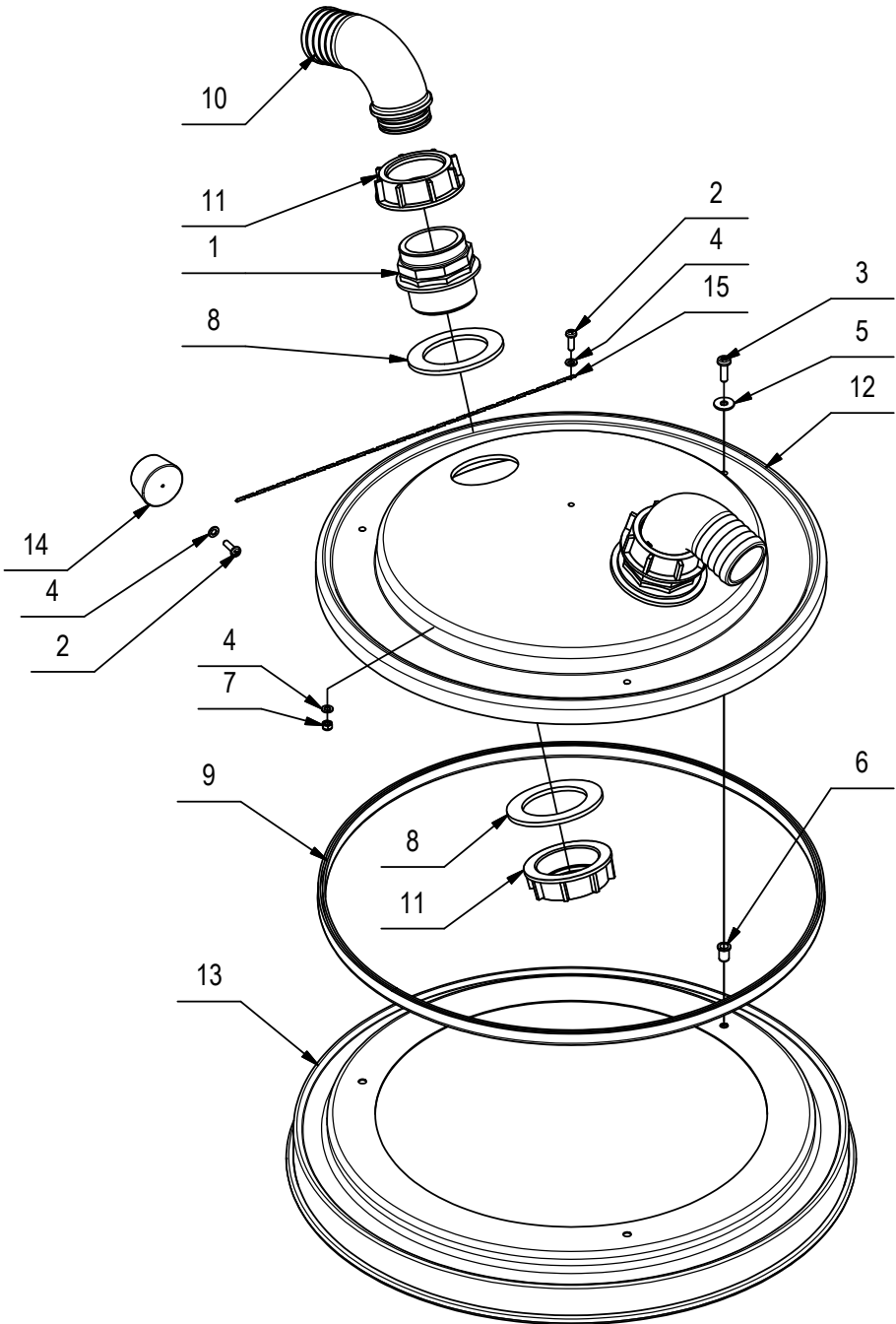

Cover Assembly (continued)

<u>Item</u>	<u>Ref. No.</u>	<u>Description</u>	<u>Qty</u>
1	TMB224842	NIPPLE, 2", BLK, PP	2
2	TMB408854	SCREW, M5 X 16MM	2
3	TMB408862	SCREW, M6 X 20MM	3
4	TMB409150	WASHER, M5 X 11MM X 1MM	3
5	TMB409160	WASHER, M6 X 18MM X 1.5MM	3
6	TMB410542	INSERT, M6 X 14	3
7	TMB416781	NUT, LOCK, M5	1
8	TMB417555	GASKET, RUBBER, 2"	4
9	TMB422554	SEAL, COVER, VAC	1
10	TMB441694	ELBOW, HOSE, 90 DEG, 2"	2
11	TMB441695	NUT, 2", BLK, PP	4
12	TMB442030	COVER, CLEAR	1
13	TMB442031	FRAME, COVER	1
14	TMB442209	PLUG, RUBBER	1
15	TMB442279	CHAIN	1

Standard Accessories

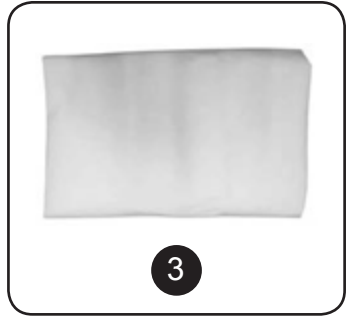

Optional Accessories



<u>Item</u>	<u>Ref. No.</u>	<u>Description</u>	<u>Qty</u>
1	TMB426778	CONE, LANCE, RUBBER	1
2	TMB427030	ADAPTER, 45 DEG, RUBBER	1
3	TMB225163	KIT, FILTER	1
4	(See Item 9)	HOSE, GREY, 2" X 25 FT	2
5	TMB400569	FITTING, CONNECTION, 2"	1
6	TMB426785	CUFF, REDUCER, 2" TO 1-1/2"	1
7	TMB416986	BAG, ACCESSORY (OPTIONAL)	1
8	TMB442337	FILTER, HEPA (OPTIONAL)	1
9	TMB225162	KIT, HOSE. 2" X 25FT (OPTIONAL)	1

Limited Warranty

AVac26 - 07213A

TO QUALIFY FOR THIS WARRANTY

- (1) Machine must be registered at the time of purchase on a form provided by American Sanders. Your American Sanders Distributor is responsible for the registration of your machine. Please cooperate with your Distributor in supplying necessary information on the card.
- (2) The machine must have been purchased from American Sanders or an authorized American Sanders Distributor.
- (3) This warranty extends to the original purchaser only and is not transferable to subsequent owners.

TIME PERIODS

- (1) ONE (1) YEAR WARRANTY - For the 07213A. Warranted to be free from defects in material and workmanship for a period of one (1) year from the date of purchase by the original owners. (See Exclusions)

EXCLUSIONS (Not Covered by Warranty)

- (1) Parts that fail through normal wear by reason of their characteristics (cords, hoses, & etc.).
- (2) This warranty does not extend to parts affected by misuse, neglect, abuse or improper maintenance. All defective parts must be returned to the distributor for credit.

THE OBLIGATION OF AMERICAN SANDERS

- (1) The obligation of American Sanders under this warranty is limited to repairing or replacing, at its option, any part which is proven to be defective in material or workmanship under normal use for the applicable period stated above.
- (2) Warranty repairs will be made by your American Sanders Distributor without charge for parts and labor. They will be compensated with a warranty labor rate of \$45.00 per hour, for the first year of ownership.
- (3) Parts repaired or replaced under this warranty are warranted only during the balance of the original warranty period. All defective parts replaced under these warranties become the property of American Sanders.

WARRANTY SERVICE

To obtain warranty service, take your machine and proof of purchase to any authorized American Sanders Distributor. American Sanders will not reimburse expenses for service calls or travel. For the Distributor in your area, call American Sanders Customer Service Department at 800-367-3550 or 336-372-8080. If you are dissatisfied with the service that you receive, call or write American Sanders Customer Service Department for further assistance.

INSTRUCTIONS AND CONDITIONS FOR WARRANTY REIMBURSEMENT

- Order replacement part: Orders will be processed and charged, as normal procedure.
- Call American Sanders for R/A number.
- You will need the Engine Serial Number, Machine Serial Number, and the Machine Model Number.
- Parts must be returned, accompanied with the R/A number to be eligible for warranty credit.
- All Warranty Parts will be shipped prepaid UPS Ground, any other method will be at the recipients expense.
- Freight on any Warranty Part after 30 days must be paid for by the Purchaser.
- Warranty labor rate is \$45.00 per hour.
- Credit will be issued upon completion of the above steps, at the above rates.

DISCLAIMER OF CONSEQUENTIAL

AMERICAN SANDERS DISCLAIMS ANY RESPONSIBILITY FOR LOSS OF USER TIME OF THE AMERICAN SANDERS MACHINE OR ANY OTHER INCIDENTAL OR CONSEQUENTIAL DAMAGE EXCEPT AS STATED IN THE WARRANTY APPLICABLE TO EACH MACHINE. EXCEPT AS STATED IN SUCH WARRANTIES, THE COMPANY DOES NOT OTHERWISE WARRANT ANY MACHINE AND NO WARRANTY, EXPRESS, IMPLIED OR STATUTORY IS MADE BY THE COMPANY.

© 2016 American Sanders



American Sanders
an AMANO Company

1 Eclipse Rd • PO Box 909
Sparta, North Carolina 28675 • USA
www.pioneereclipse.com
www.americansander.com

+1-336-372-8080
1-800-334-2246