



ATTIX 30 / BATT / PC / XC

ATTIX 40 / PC / XC

ATTIX 50 / PC / XC

Operating Instructions

Nilfisk
ALTO
Why Compromise



ATTIX 30

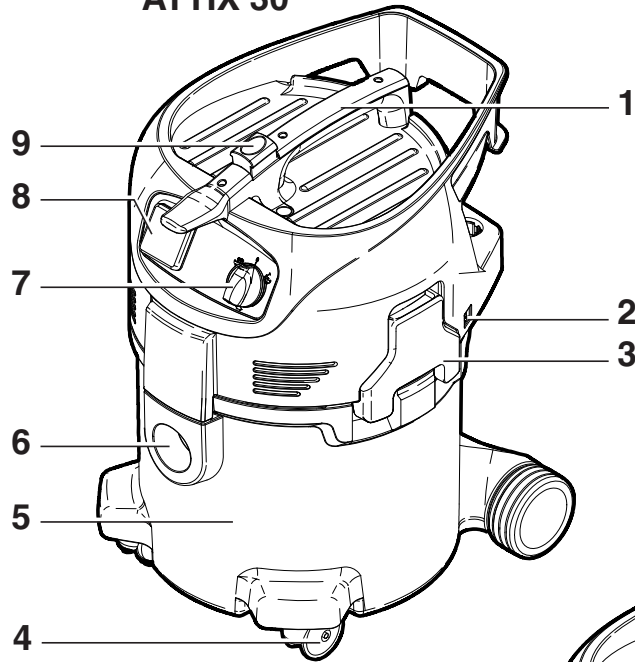

ATTIX 50

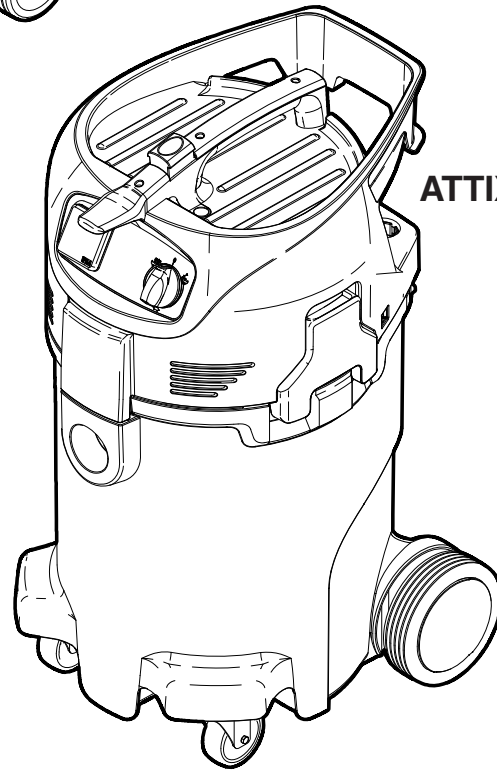

ATTIX 40

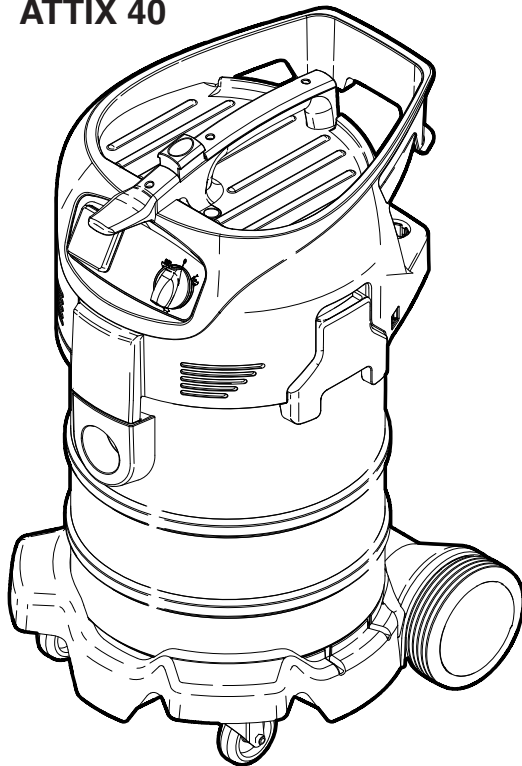



Contents

| | | | |
|----------|--------------------------------------|--|----|
| 1 | Important safety instructions | | 2 |
| 2 | Description | 2.1 Operating elements..... | 6 |
| | | 2.2 Operating panel..... | 7 |
| 3 | Before starting the cleaner | 3.1 Assembling the vacuum cleaner..... | 8 |
| | | 3.1.1 Taking accessories out of the packaging ¹⁾ | 8 |
| | | 3.1.2 Attaching the suction pipe holder to the suction pipe ¹⁾ | 8 |
| | | 3.2 Loading and inserting the battery (ATTIX 30-01 PC BATT)..... | 8 |
| | | 3.3 Inserting the filter bag..... | 9 |
| 4 | Control / Operation | 4.1 Connections..... | 11 |
| | | 4.1.1 Connecting the suction hose..... | 11 |
| | | 4.1.2 Electrical connection..... | 11 |
| | | 4.2 Switching on the vacuum cleaner..... | 11 |
| | | 4.2.1 Switch „0-I“ ¹⁾ | 11 |
| | | 4.2.2 Switch „auto-0-I“ ¹⁾ | 11 |
| | | 4.2.3 Suction power control ¹⁾ | 12 |
| | | 4.2.4 Auto-On/Off-Operation - "auto" switch position ¹⁾ | 12 |
| | | 4.3 Cleaning the filter element..... | 13 |
| | | 4.3.1 Cleaning the filter element " Push&Clean System " (ATTIX 30- / 40- / 50-xx PC)..... | 13 |
| | | 4.3.2 Cleaning the filter element " XtremeClean " (ATTIX 30- / 40- / 50-xx XC)..... | 13 |
| 5 | Applications and methods | 5.1 Techniques..... | 14 |
| | | 5.1.1 Picking up dry substances..... | 14 |
| | | 5.1.2 Picking up liquids..... | 14 |
| 6 | After using the cleaner | 6.1 Switching the vacuum cleaner off and storage..... | 15 |
| 7 | Maintenance | 7.1 Maintenance plan..... | 16 |
| | | 7.2 Maintenance work..... | 16 |
| | | 7.2.1 Emptying the dirt tank..... | 16 |
| | | 7.2.2 Replacing the filter bag..... | 17 |
| | | 7.2.3 Replacing the disposal bag..... | 18 |
| | | 7.2.4 Replacing filter element (Push & Clean System)..... | 19 |
| | | 7.2.5 Replacing filter element (XtremeClean System)..... | 20 |
| 8 | Troubleshooting | | 21 |
| 9 | Further information | 9.1 Recycling the cleaner..... | 22 |
| | | 9.2 Guarantee..... | 22 |
| | | 9.3 Tests and approvals..... | 22 |
| | | 9.4 EC declaration of conformity..... | 22 |
| | | 9.5 Technical data..... | 23 |
| | | 9.6 Optional accessories..... | 23 |



¹⁾Optional accessories / Option depending on model

EN 1 Important safety instructions

Symbols used to mark instructions



Prior to using the appliance for the first time, be sure to read this document through and keep it ready to hand.

| | |
|---|--|
|  | DANGER |
| | Danger that leads directly to serious or irreversible injuries, or even death. |
|  | WARNING |
| | Danger that can lead to serious injuries or even death. |
|  | CAUTION |
| | Danger that can lead to minor injuries and damage. |

The appliance must

- only be used by persons, who have been instructed in its correct usage and explicitly commissioned with the task of operating it
- only be operated under supervision
- not be used by children

1. Do not use any unsafe work techniques.
2. Never use the vacuum cleaner without a filter.
3. Switch off the appliance and disconnect the mains plug in the following situations:
 - Prior to cleaning and servicing
 - Prior to replacing components
 - Prior to changing over the appliance
 - If foam develops or liquid emerges

Besides the operating instructions and the binding accident prevention regulations valid in the country of use, observe recognised regulations for safety and proper use.

Purpose and intended use

The appliance is suitable for picking up dry, non-flammable dust and liquids.

The appliance is suitable for commercial use, such as e.g. in

- Hotels, Schools, Hospitals, Factories, Shops, Offices, Hire shops

Any other use is considered as improper use. The manufacturer accepts no liability for any damage resulting from such use. The risk for such use is borne solely by the user.

Proper use also includes proper operation, servicing and repairs as specified by the manufacturer.



Transport

1. Before transporting the dirt tank, close all the locks.
2. Do not tilt the cleaner if there is liquid in the dirt tank.
3. Do not use a crane hook to lift the cleaner.

Storage

1. Store the appliance in a dry place, protected from frost.

Electrical connection

1. It is recommended that the vacuum cleaner should be connected via a residual current circuit breaker.
2. Arrange the electrical parts (sockets, plugs and couplings) and lay down the extension lead so that the protection class is maintained.
3. Connectors and couplings of power supply cords and extension leads must be watertight.

Extension lead

1. As an extension lead, only use the version specified by the manufacturer or one of a higher quality.
2. When using an extension lead, check the minimum cross-sections of the cable:

| Cable length | Cross section | |
|--------------|---------------------|---------------------|
| | < 16 A | < 25 A |
| up to 20 m | 1.5 mm ² | 2.5 mm ² |
| 20 to 50 m | 2.5 mm ² | 4.0 mm ² |

Battery Charger

Only use the battery which is delivered with the charger. Other types of batteries could cause an explosion. Do not attempt to charge alkaline batteries or other types of primary batteries. Do not dispose of batteries in fire as the battery may explode, leak or catch fire.

Keep the charger in a dry place (indoor use only). In order to avoid the risk of fire or electrical shock, the charger must be protected against high humidity and water.

The charger must

- not be used if plug or cover are defective
- not be opened or converted
- kept away from children
- not be used unattended
- be disconnected after use
- be cleaned with a soft cloth only after the plug is disconnected
- be repaired only by authorised personnel

Warranty

Our general conditions of business are applicable with regard to the guarantee.





Unauthorised modifications to the appliance, the use of incorrect brushes in addition to using the appliance in a way other than for the intended purpose exempt the manufacturer from any liability for the resulting damage.

Tests and approvals

Electrical tests must be performed in accordance with the provisions of safety regulations (BGV A3) and to DIN VDE 0701 Part 1 and Part 3. In accordance with DIN VDE 0702 these tests must be performed at regular intervals and after repairs or modifications.

EN Risks

Electrical components

| | |
|---|---|
|  | DANGER |
| | <p>Electric shock due to faulty mains connecting lead. Touching a faulty mains connecting lead can result in serious or even fatal injuries.</p> <ol style="list-style-type: none"> 1. Do not damage the mains power lead (e.g. by driving over it, pulling or crushing it). 2. Regularly check whether the power cord is damaged or shows signs of ageing. 3. Have the faulty mains connecting lead replaced by your Nilfisk-Alto service representative or a qualified electrician prior to using the appliance again. |
|  | DANGER |
| | <p>The upper section of the vacuum cleaner contains live components. Contact with live components leads to serious or even fatal injuries.</p> <ol style="list-style-type: none"> 1. Never spray water on to the upper section of the vacuum cleaner. |
|  | CAUTION |
| | <p>Appliance socket¹⁾. The appliance socket is only designed for the purposes defined in the operating instructions. The connection of different appliances can result in damage.</p> <ol style="list-style-type: none"> 1. Prior to plugging in an appliance, always switch off the vacuum cleaner and the appliance that is to be connected. 2. Read the operating instructions to the appliance to be connected and observe the safety notes contained in these. |
|  | CAUTION |
| | <p>Damage due to unsuitable mains voltage. The appliance can be damaged as a result of being connected to an unsuitable mains voltage.</p> <ol style="list-style-type: none"> 1. Ensure that the voltage shown on the rating plate corresponds to the voltage of the local mains power supply. |

Picking up liquids

| CAUTION | |
|---|---|
|  | <p>Picking up liquids. Do not pick up flammable liquids.</p> <ol style="list-style-type: none"> 1. Before liquids are picked up, always remove the filter bag/waste bag and check that the float ¹⁾ or the water level limit ¹⁾ works properly. 2. The use of a separate filter element or filter screen is recommended. 3. If foam appears, stop work immediately and empty the tank. |

Hazardous materials

| WARNING | |
|---|--|
|  | <p>Hazardous materials. Vacuuming up hazardous materials can lead to serious or even fatal injuries</p> <ol style="list-style-type: none"> 1. The following materials must not be picked up by the vacuum cleaner: <ul style="list-style-type: none"> - hazardous dust - hot materials (burning cigarettes, hot ash, etc.) - flammable, explosive, aggressive liquids (e.g. petrol, solvents, acids, alkalis, etc.) - flammable, explosive dust (e.g. magnesium or aluminium dust, etc.) |

Spare parts and accessories

| CAUTION | |
|--|---|
|  | <p>Spare parts and accessories. The use of non-genuine spare parts and accessories can impair the safety of the appliance.</p> <ol style="list-style-type: none"> 1. Only use spare parts and accessories from Nilfisk-Alto. 2. Use only the brushes supplied with the vacuum cleaner or specified in the operating manual. |

Emptying dirt tank

| CAUTION | |
|---|--|
|  | <p>Picking up environmentally hazardous materials. Materials picked up can present a hazard to the environment.</p> <ol style="list-style-type: none"> 1. Dispose of the dirt in accordance with legal regulations. |

¹⁾Optional accessories / Option depending on model

EN 2 Description

2.1 Operating elements

- 1 Handle with receptacle for electrical lead
- 2 Fixing point for suction pipe holder
- 3 Retaining clamp
- 4 Castor
- 5 Dirt tank
- 6 Inlet fitting
- 7 Appliance switch
- 8 Appliance socket ¹⁾
- 9 Operating knob for filter cleaning ¹⁾

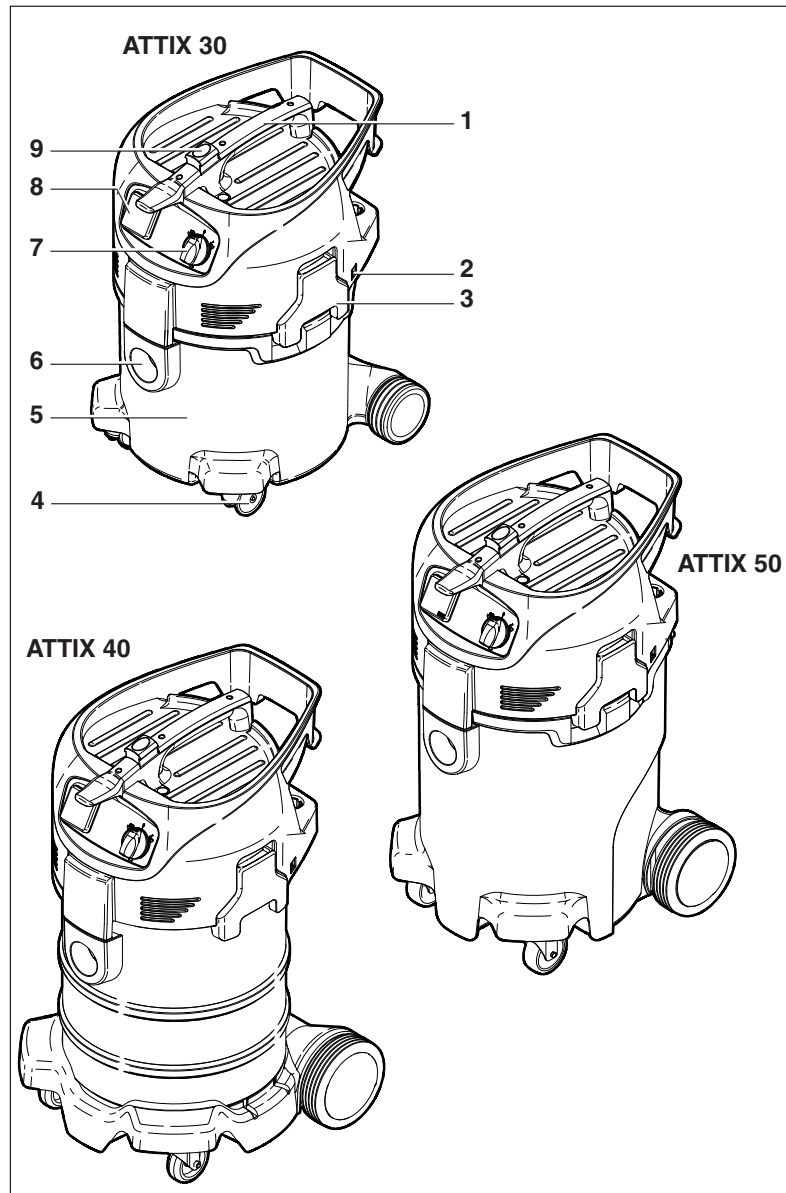

2.2 Operating panel

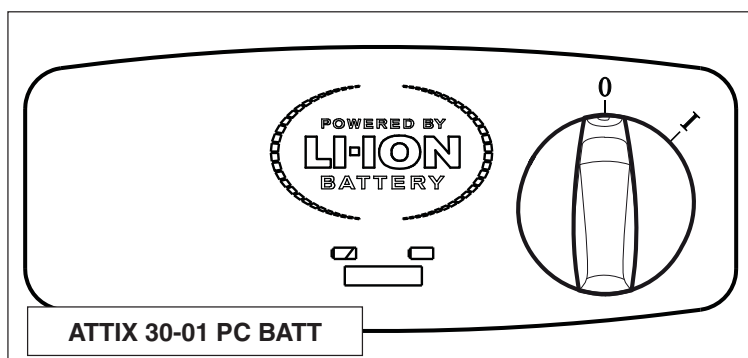
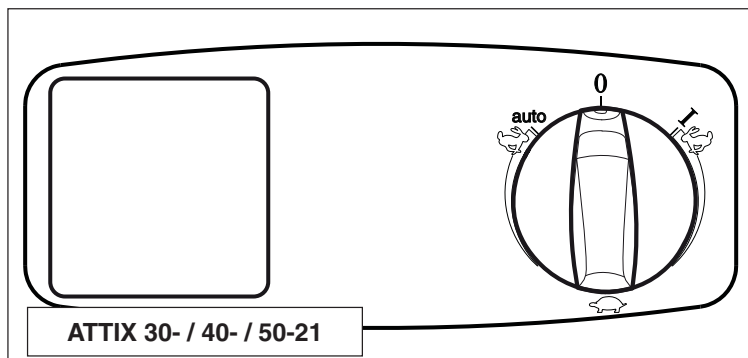
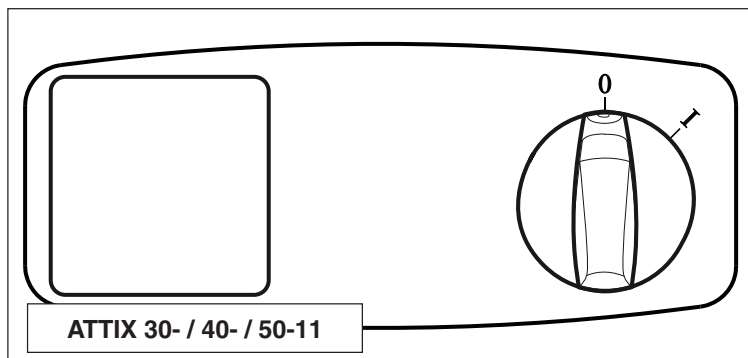
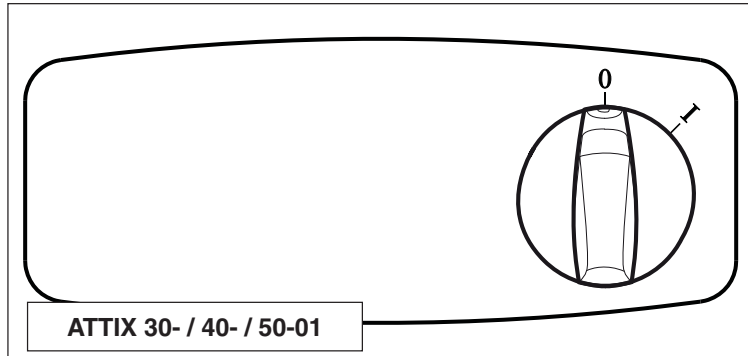

¹⁾Optional accessories / Option depending on model

EN 3 Before starting the cleaner

3.1 Assembling the vacuum cleaner

3.1.1 Taking accessories out of the packaging ¹⁾

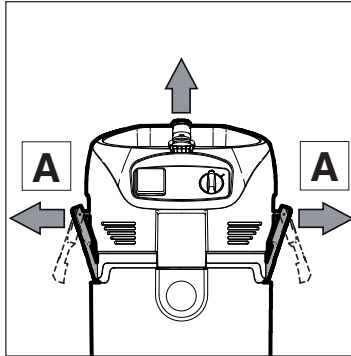

1. Take vacuum cleaner and accessories out of the packaging.
2. The mains plug should not yet be inserted into a socket.
4. Open the retaining clamps (B) and remove the upper section of the vacuum cleaner.
5. Take the accessories ¹⁾ out of the dirt tank and the packaging.

3.1.2 Attaching the suction pipe holder to the suction pipe ¹⁾

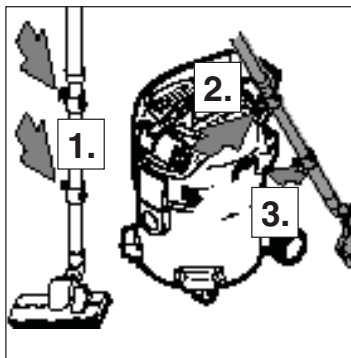

1. Attach the suction pipe holder to the suction pipe.

3.2 Loading and inserting the battery (ATTIX 30-01 PC BATT)

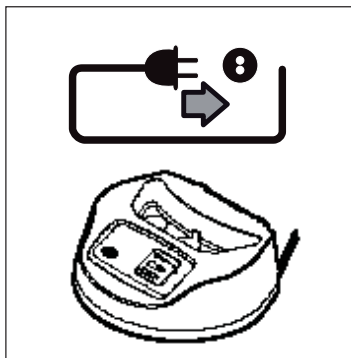

1. Insert the power cord of the charger into a properly installed and fused socket with earthing contact.

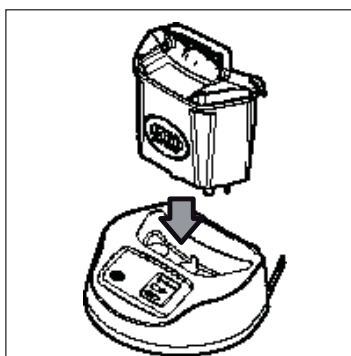

2. Insert the battery into the charger.

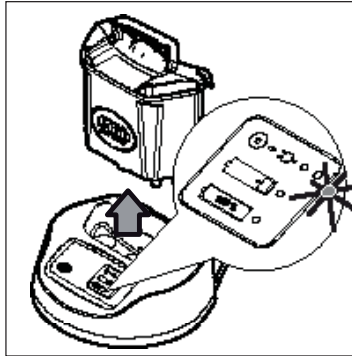

3. Remove the battery from the charger after completion of the charging process (LED 100% lights up).

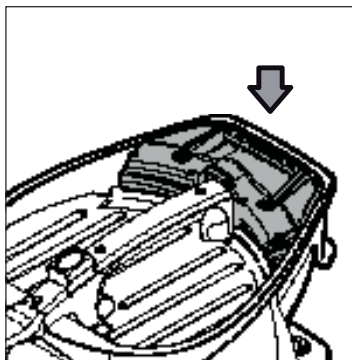

4. Insert the battery into the machine and fix it by turning down the carrying handle.

3.3 Inserting the filter bag

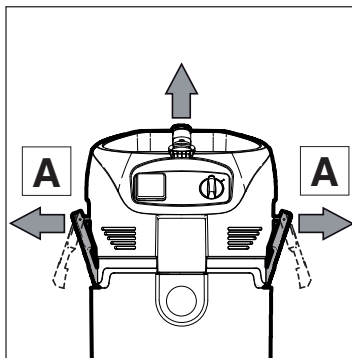

1. The mains plug should not yet be inserted into a socket.
2. Open the retaining clamps (A) and remove the upper section of the vacuum cleaner.

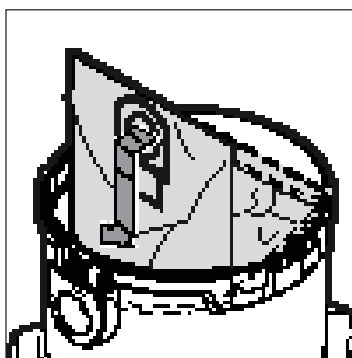

3. Insert the filter bag into the dirt tank.

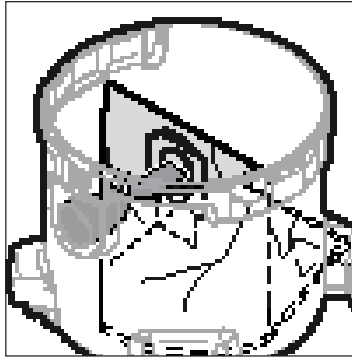

4. Press the filter bag connection firmly on to the inlet fitting.

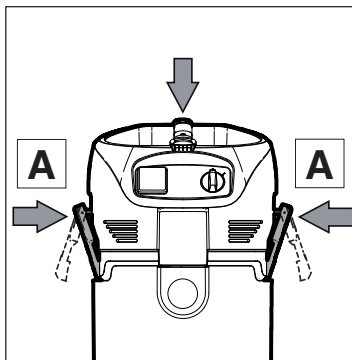

5. Attach the upper section of the vacuum cleaner.
6. Close the retaining clamps (A). Ensure that the retaining clamps fit properly.

4 Control / Operation

4.1 Connections

4.1.1 Connecting the suction hose

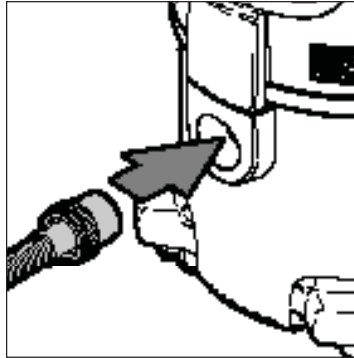

1. Connect the suction hose.

4.1.2 Electrical connection

The operating voltage shown on the rating plate must correspond to the voltage of the mains power supply.

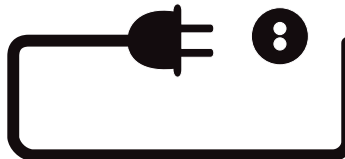

1. Ensure that the cleaner is switched off.
2. Insert the power cord into a properly installed and fused socket with earthing contact.

4.2 Switching on the vacuum cleaner

4.2.1 Switch „0-I“¹⁾

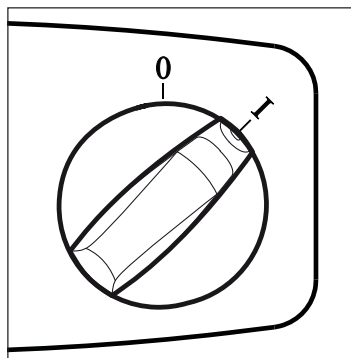

| Switch position | Function |
|-----------------|----------|
| 0 | Off |
| I | On |

4.2.2 Switch „auto-0-I“¹⁾

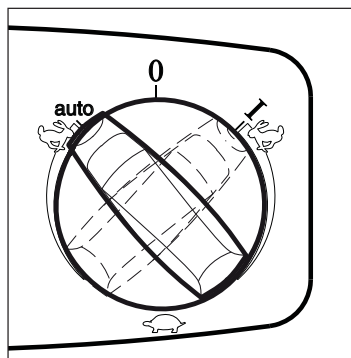



| Switch position | Function |
|-----------------|--|
| 0 | Off |
| auto |  Auto On/Off |
| I | On / manual mode |

¹⁾Optional accessories / Option depending on model

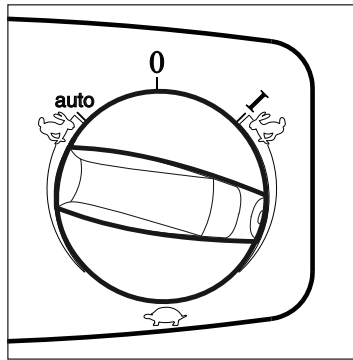

4.2.3 Suction power control ¹⁾



| Switch position | Function |
|---|---|
|  | The suction power control switch allows precise adaptation of the suction power for different cleaning tasks. |

4.2.4 Auto-On/Off-Operation - "auto" switch position ¹⁾

The vacuum cleaner is switched on and off by the power tool connected. Dirt is picked up from the source of dust immediately.

To comply with regulations, only approved dust producing tools should be connected.

The maximum power consumption of the connected electrical appliance is stated in section "Technical data".

Before switching the switch to position „auto“, ensure that the tool connected to the appliance socket is switched off.

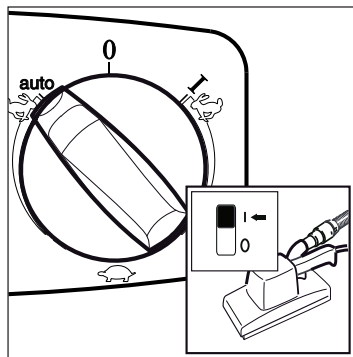
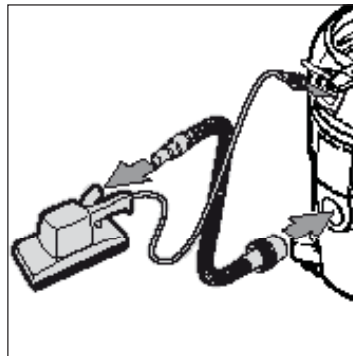
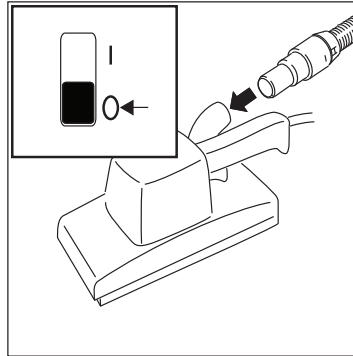

1. Switch off the vacuum cleaner.
2. Switch off the power tool.
3. Connect the power tool and the vacuum cleaner with a suction hose.
4. Insert the plug of the power tool into the tool socket on the operating panel of the vacuum cleaner.
5. Switch on the vacuum cleaner. Switch in "auto" position.
6. Switch on the power tool. The vacuum cleaner motor starts when the connected power tool is switched on. When the power tool is switched off, the vacuum cleaner continues to run for a short moment so that any dust in the suction hose is conveyed to the filter bag.

4.3 Cleaning the filter element
4.3.1 Cleaning the filter element
" Push&Clean System "
(ATTIX 30- / 40- / 50-xx PC)

Only for vacuum cleaning without a filter bag and without a cloth insert filter.



EN

If suction performance drops:

1. Turn switch to position "I" (maximum suction power).
2. Close the nozzles or suction hose opening with the palm of your hand.
3. Press the button to start filter cleaning three times. The resulting stream of air removes attached dust from the slats of the filter elements.

4.3.2 Cleaning the filter element " XtremeClean "
(ATTIX 30- / 40- / 50-xx XC)

Only for vacuum cleaning without a cloth insert filter.



To ensure that suction performance is always at its best, the filter element is automatically cleaned during operation. We recommend complete cleaning if the filter element becomes extremely dirty.

1. Switch off the vacuum cleaner
2. Close the nozzles or suction hose opening with the palm of your hand.
3. Turn the switch to position „I“ and let the cleaner operate for approx. 10 seconds with the suction hose opening closed.

EN 5 Applications and techniques

5.1 Techniques

If used correctly, additional accessories, suction nozzles and suction hoses can enhance the cleaning action and reduce the cleaning effort.

Effective cleaning is achieved if you follow just a few guidelines in combination with your own practical experience in special fields.

Here are some basic tips.

5.1.1 Picking up dry substances

Before picking up dry substances, always ensure that a filter bag is inserted in the tank (see section "Accessories" for order number). Disposal of the picked up material is then simple and hygienic.

After picking up liquids, the filter element is wet. A damp filter element clogs more quickly when dry substances are picked up. For this reason the filter element should be washed and dried or replaced by a dry element before dry substances are picked up.

5.1.2 Picking up liquids

Before liquids are picked up, always remove the filter bag/disposal bag.

The use of a separate filter element or filter screen is recommended.

If foam appears, stop work immediately and empty the tank.

To reduce the amount of foam, use foam killer Nilfisk-Alto Foam Stop (see section "Accessories" for order number).

6 After finishing work

6.1 Switching the vacuum cleaner off and storage

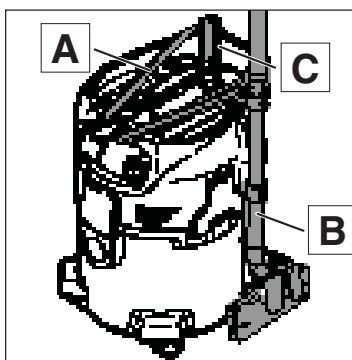
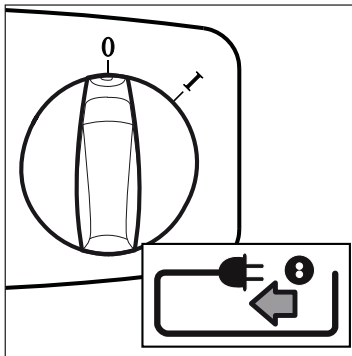

1. Switch off the cleaner and pull the mains plug out of the socket.
2. Wind up the power cord onto the handle (A). Begin winding up the cord at the cleaner end and not the plug end to prevent the power cord from tangling up.
3. Empty the dirt tank and clean the vacuum cleaner.
4. After picking up liquids: Store the upper section of the vacuum cleaner separately so that the filter element can dry.
5. Hang the suction hose with the floor nozzle (B) in the brackets and pack the accessories (C) away.
6. Store the cleaner in a dry room where it is protected from unauthorized use.

EN 7 Maintenance

7.1 Maintenance plan

| | | After finishing work | When required |
|-------|--|----------------------|---------------|
| 7.2.1 | Emptying dirt tank | ● | |
| 7.2.2 | Replacing the filter bag | | ● |
| 7.2.3 | Replacing the disposal bag | | ● |
| 7.2.4 | Replacing filter element (Push&Clean) | | ● |
| 7.2.5 | Replacing filter element (XtremeClean) | | ● |

7.2 Maintenance work

7.2.1 Emptying the dirt tank

After emptying the tank: clean the rim of the tank and the seals in the intermediate ring and the upper section of cleaner before refitting them. If the seal or groove is dirty or damaged, the suction performance will be reduced.

Before reinserting the suction hose: clean the inlet fitting and hose collar.

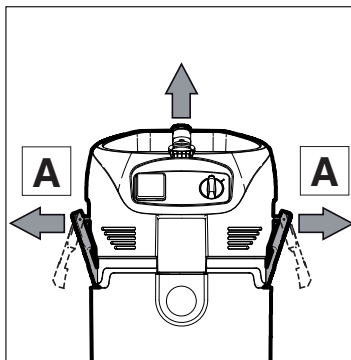

1. Switch off the vacuum cleaner and pull the mains plug out of the socket.
2. Open the retaining clamps (A) and remove the upper section of the vacuum cleaner.

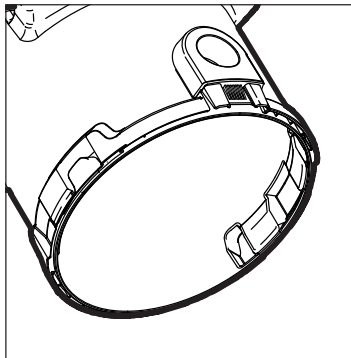

3. Tip out the collected dirt.
4. Dispose of the dirt in accordance with legal regulations.

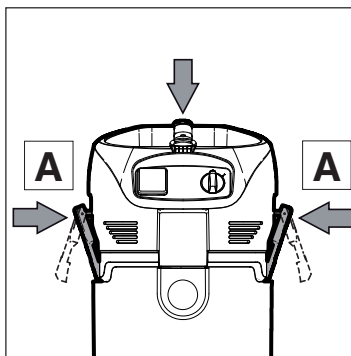

5. Attach the upper section of the vacuum cleaner.
6. Close the retaining clamps (B). Ensure that the retaining clamps fit properly.

7.2.2 Replacing the filter bag

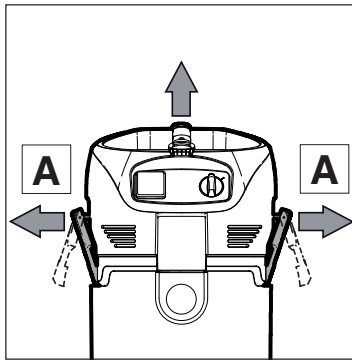

1. Switch off the vacuum cleaner and pull the mains plug out of the socket.
2. Open the retaining clamps (A) and remove the upper section of the vacuum cleaner.

EN

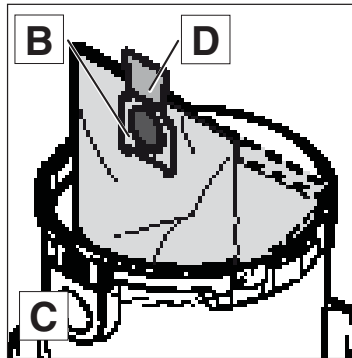

Removing the filter bag:

3. Carefully remove the filter bag connection from the inlet fitting (C).
4. Close the filter bag connection (D) with the slider.
5. Dispose of the filter bag in accordance with legal regulations.



Inserting the filter bag:

6. Clean the dirt tank.
7. Insert the filter bag in the dirt tank.
8. Press the bush of the new filter bag firmly on to the inlet fitting (C).

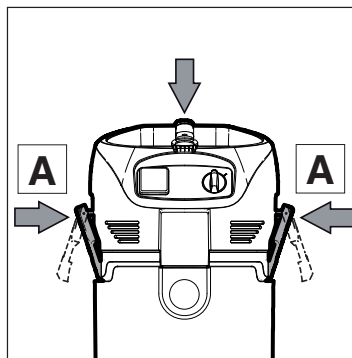

9. Attach the upper section of the vacuum cleaner.
10. Close the retaining clamps (B). Ensure that the retaining clamps fit properly.



7.2.3 Replacing the disposal bag

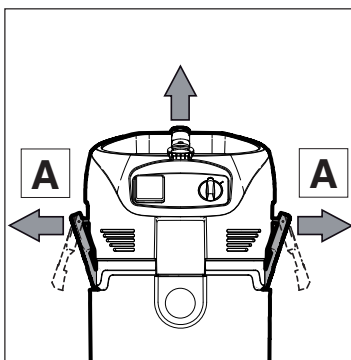

1. Switch off the vacuum cleaner and pull the mains plug out of the socket.
2. Open the retaining clamps (A) and remove the upper section of the vacuum cleaner.

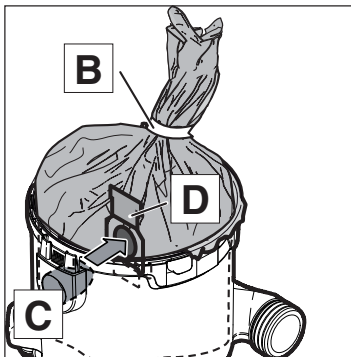

Removing the disposal bag:

3. Close the disposal bag with string (B).
4. Carefully remove the filter bag connection from the inlet fitting (C).
5. Close the disposal bag connection (D) with the slider.
6. Dispose of the disposal bag in accordance with legal regulations.

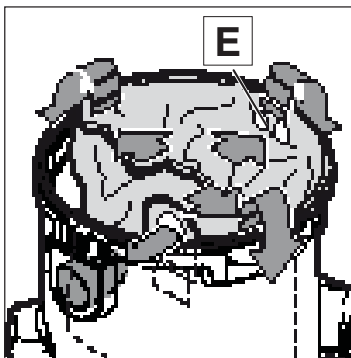

Inserting the disposal bag:

7. Clean the dirt tank.
8. Insert the disposal bag into the dirt tank.
9. Check that the ventilation holes (E) remain inside the dirt tank.
10. Press the bush of the new filter bag firmly on to the inlet fitting.
11. Fold the top edge of the disposal bag over the rim of the dirt tank.

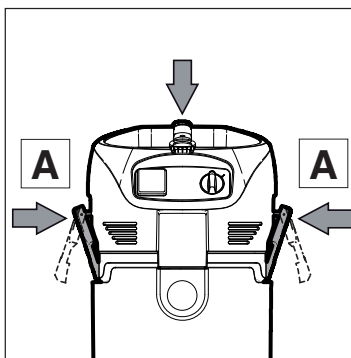

12. Attach the upper section of the vacuum cleaner.
13. Close the retaining clamps (A). Ensure that the retaining clamps fit properly.

7.2.4 Replacing filter element (Push & Clean System)

Never use the vacuum cleaner without a filter.

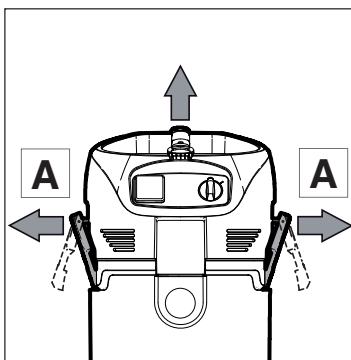

1. Switch off the vacuum cleaner and pull the mains plug out of the socket.
2. Open the retaining clamps (A) and remove the upper section of the vacuum cleaner.

EN

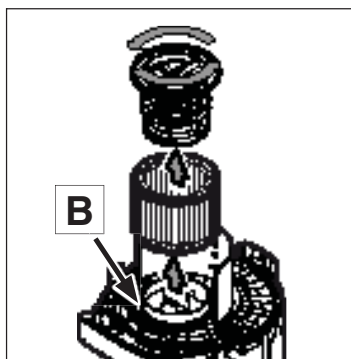

Removing the filter element:

3. Turn the filter holder anticlockwise and remove it.
4. Carefully remove the filter element.
5. Clean the filter seal (B). Check it for damage and replace it if necessary.

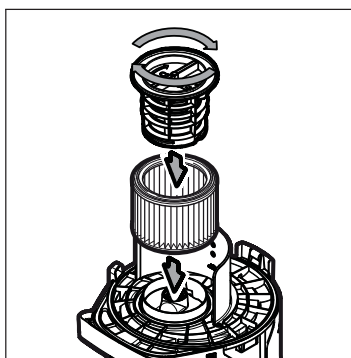

Inserting the filter element:

6. Fit the filter holder and turn it clockwise to secure it.
7. Fit the filter holder and turn it clockwise to secure it.
8. Dispose of the used filter element in accordance with legal regulations.

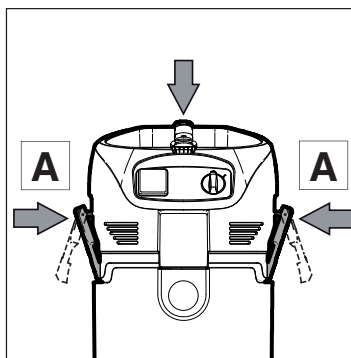

9. Attach the upper section of the vacuum cleaner.
10. Close the retaining clamps (A). Ensure that the retaining clamps fit properly.



7.2.5 Replacing filter element (XtremeClean System)

Never use the vacuum cleaner without a filter.

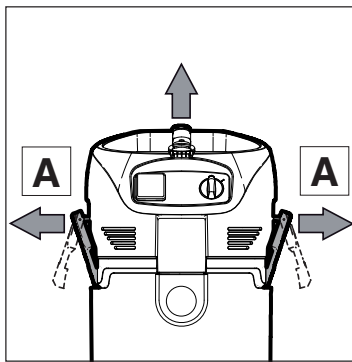

1. Switch off the vacuum cleaner and pull the mains plug out of the socket.
2. Open the retaining clamps (A) and remove the upper section of the vacuum cleaner.

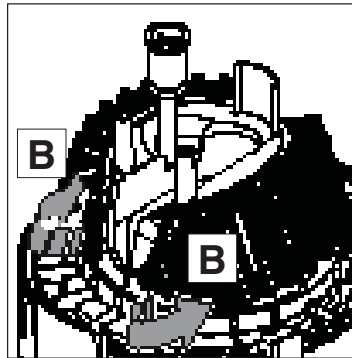

Removing the filter elements:

3. Open filter tension part (B).
4. Remove carefully the cassettes with filter elements.

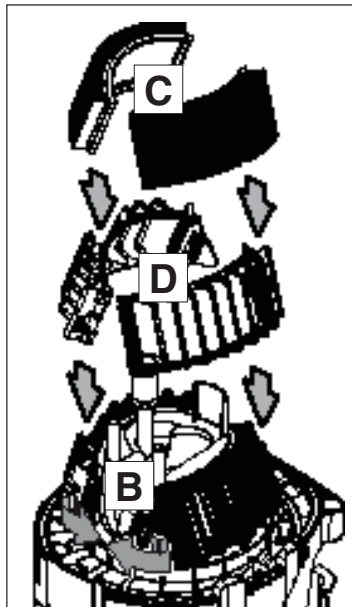

Inserting the filter elements:

5. Insert new filter elements (C) into the cassettes (D).
6. Attach the cassettes with the filter elements onto the upper section of the vacuum cleaner.
7. Fix the filter tension part (B).
8. Dispose of the used filter elements in accordance with legal regulations.

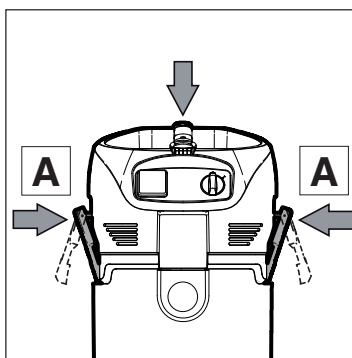

9. Attach the upper section of the vacuum cleaner.
10. Close the retaining clamps (A). Ensure that the retaining clamps fit properly.

8 Troubleshooting



| Fault | Cause | Remedy |
|--|--|--|
| ‡ Motor does not start | <ul style="list-style-type: none"> > Fuse of the mains socket has blown. > Overload protection switch has tripped. > Motor is faulty. | <ul style="list-style-type: none"> • Connect mains fuse. • Switch off the vacuum cleaner and allow it to cool for approx. 5 minutes. If the cleaner cannot be started again, contact the Nilfisk-Alto service department. • Have motor changed by Nilfisk-Alto Service. |
| ‡ Motor does not run in automatic mode ¹⁾ | <ul style="list-style-type: none"> > Power tool/pneumatic tool is defective or not connected properly. > The power rating of the electrical tool is too low. | <ul style="list-style-type: none"> • Check that the power tool works or that the plug is inserted correctly. • Note that minimum power rating is P>40W |
| ‡ Reduced suction power | <ul style="list-style-type: none"> > Suction power selected with suction power control¹⁾ is too low. > Clogged suction hose/nozzle. > Tank, disposal bag or filter bag is full. > Filter element is clogged. > Seal between tank and upper section of vacuum cleaner is faulty or missing. > Cleaning mechanism is defective. | <ul style="list-style-type: none"> • Set suction power in accordance with section „Setting suction power“. • Clean suction hose/nozzle • See "Emptying tank" or "Replacing disposal bag, filter bag" sections. • See section „Cleaning filter element“ and „Replacing filter element“. • Replace seal. • Contact Nilfisk-Alto Service. |
| ‡ No suction power during wet cleaning | <ul style="list-style-type: none"> > Tank is full. | <ul style="list-style-type: none"> • Switch off the cleaner. Empty the tank. |
| ‡ Voltage fluctuations | <ul style="list-style-type: none"> > Impedance of power supply is too high. | <ul style="list-style-type: none"> • Connect the cleaner to another socket closer to the fuse box. Voltage fluctuations over 7% should not occur if the impedance at the transfer point is $\leq 0.15 \Omega$. |

¹⁾ Optional accessories / Option depending on model

9 Further information

9.1 Recycling the cleaner

Make the old cleaner unusable immediately.

1. Unplug the cleaner.
2. Cut the power cord.
3. Do not discard of electrical appliances with household waste.



As specified in European Directive 2002/96/EC on old electrical and electronic appliances, used electrical goods must be collected separately and recycled ecologically. Contact your local authorities or your nearest dealer for further information.

9.2 Guarantee

Our general conditions of business are applicable with regard to the guarantee.



Unauthorised modifications to the appliance, the use of incorrect brushes in addition to using the appliance in a way other than for the intended purpose exempt the manufacturer from any liability for the resulting damage.

9.3 Tests and approvals

Electrical tests must be performed in accordance with the provisions of safety regulations (BGV A3) and to DIN VDE 0701 Part 1 and Part 3. In accordance with DIN VDE 0702 these tests must be performed at regular intervals and after repairs or modifications.

The vacuum cleaner has been approved in accordance with IEC/EN 60335-2-69.

9.4 EC declaration of conformity

|  | EC declaration of conformity |
|---|--|
| ALTO Deutschland GmbH Guido-Oberdorfer-Straße 2-8 D-89287 Bellenberg | |
| Product: | Vacuum cleaner for wet and dry operation |
| Model: | ATTIX 30 / 40 / 50 |
| Description: | 230-240 V~, 50/60 Hz |
| The design of the appliance corresponds to the following pertinent regulations: | EC Machine Directive 2006/42/EC EC Low Voltage Directive 2006/95/EC EC EMC Directive 2004/108/EC |
| Applied harmonized standards: | EN ISO 12100-1, EN ISO 12100-2 EN 60335-1 EN 60335-2-69 EN 55014-1, EN 55014-2, EN 61000-3-2 |
| Applied national standards and technical specifications: | IEC 60335-2-69 |
|  Dipl. Ing. Wolfgang Nieuwkamp Tests and approvals | Bellenberg, 02.01.2008 |

9.5 Technical data



| | | ATTIX 30 / 40 / 50 | | | | | |
|----------------------------------|----|--------------------|--------|--------------|----------|----------|---------|
| | | EU | CH, DK | GB 230/240 V | GB 110 V | US 120 V | Charger |
| Voltage | V | 230 | | 230/240 | 110 | 120 | 100-240 |
| Mains frequency | Hz | 50/60 | | | | 60 | 50-60 |
| Fuse | A | 16 | 10 | 13 | 16 | 15 | |
| Power consumption _{IEC} | W | 1200 | | | 1000 | | 50 |

| | | ATTIX | | | | | | | |
|---|----------------------|---|----------|-------------------------------|--|----------------------|--|---------------|--------------|
| | | 30-01 30-01 PC | 40-01 PC | 50-01 PC | 30-11 PC 30-21 PC 30-21 XC | 40-21 PC 40-21 XC | 50-21 PC 50-21 XC | 30-01 BATT | Charg- er |
| Connected load for appliance socket | W | - | | | 2400 | | | | - |
| Total connected load | W | 1200 | | | 3600 | | | | 50 |
| Air flow rate | l/min | | | | 3700 (PC) 3800 (XC) | | | 2220 | |
| Vacuum | mbar | 250 | | | | | | 137 | |
| Sound pressure level at a distance of 1 m, EN 60704-1 | dB(A) | 62 | | | | | | | |
| Sound level | dB(A) | 59 | | | | | | | |
| Power cord: Length | | 7,5 | | | | | | | |
| Power cord: Type | | 1) (EU,CH) 2) (GB 110 V) 3) (GB 230 V) 4) (US) | 5) (EU) | 5) (EU) 6) (CH) 7) (US) | 5) (EU,DK) 8) (GB 110V) 5) (GB 230V) 6) (CH) 7) (US) | 5) (EU,DK) | 5) (EU,DK) 8) (GB 110V) 5) (GB 230V) 6) (CH) 7) (US) | | |
| Protection class | | II | | | I | | | II | |
| Type of protection | | IP X4 (splash water protected) | | | | | | | |
| Radio interference level | | EN 55014-1 | | | | | | | |
| Tank volume | l | 30 | 36 | 45 | 30 | 36 | 45 | 30 | |
| Width | mm | 360 | 440 | 360 | 360 | 440 | 360 | | 300 |
| Depth | mm | 450 | 450 | 450 | 450 | 450 | 450 | | 262 |
| Height | mm | 600 | 740 | 750 | 600 | 740 | 750 | | 106 |
| Weight | kg | 10 | 12 | 11 | 10 (PC) 11 (XC) | 12 (PC) 13 (XC) | 11 (PC) 12 (XC) | 13 | 1 |
| 1) = H05RRR-F 2x0,75 | 3) = H05RRR-F 2x0,75 | | | 5) = H05RRR-F 3G1,5 | | | 7) = SJTW-A AWG 14/3 | | |
| 2) = H05BQ-F 2x1,0 | 4) = SJTW-A AWG 18/2 | | | 6) = H05RRR-F 3G1,0 | | | 8) = H07BQ-F 3G2,5 | | |

9.6 Optional accessories

| Description | Order No. |
|---|-----------|
| Fleece filter bag Attix 30 (5 pcs.) | 302004000 |
| Fleece filter bag Attix 40, 50 (5 pcs.) | 302004004 |
| Disposal bag Attix 30, 40, 50 (5 pcs.) | 302000728 |
| Zylindrical filter element PC | 302000461 |
| Flat filter element XC (2 Stück) | 302002842 |
| Cloth insert filter Attix 30 | 302000525 |
| Cloth insert filter Attix 50 | 302000606 |
| Nilfisk-Alto-Foam-Stop (6x1l) | 8469 |

¹⁾ Optional accessories / Option depending on model

Nilfisk ALTO

Why Compromise

<http://www.nilfisk-alto.com>

HEAD QUARTER

DENMARK

Nilfisk-Advance Group
Sognevej 25
DK-2605 Brøndby
Tel.: +45 4323 8100
Fax: +45 4343 7700
E-mail: mail.com@nilfisk-advance.dk

SALES COMPANIES

AUSTRALIA

Nilfisk-ALTO
48 Egerton St.
P.O. Box 6046
Silverwater, N.S.W. 2128
Tel.: +61 2 8748 5966
Fax: +61 2 8748 5960

AUSTRIA

Nilfisk-Advance GmbH
Nilfisk-ALTO
Metzgerstrasse 68
5101 Berghheim/Salzburg
Tel.: +43 662 456 400-0
Fax: +43 662 456 400-34
E-mail: info@nilfisk-alto.at
www.nilfisk-alto.at

BELGIUM

Nilfisk-ALTO
Division of Nilfisk-Advance n.v.s.a.
Internationalelaan 55 (Gebouw C3/C4)
1070 Brussel
Tel.: +32 02 467 60 40
Fax: +32 02 466 61 50
E-mail: info.be@nilfisk-alto.com

CANADA

Clarke Canada
Part of the Nilfisk-Advance Group
4080 B Sladeview Crescent, Unit 1
Mississauga, Ontario L5L 5Y5
Tel.: +1 905 569 0266
Fax: +1 905 569 8586

CHINA

Nilfisk-Advance (Shenzhen) Ltd.
Blok 3, Unit 130 1001 Honghua Road
Int. Commercial & Trade Center
Fuitian Free Trade Zone
518038 Shenzhen
Tel.: +86 755 8359 7937
Fax: +86 755 8359 1063

CZECH REPUBLIC

ALTO Česká Republika s.r.o.
Zateckých 9
14000 Praha 4
Tel.: +420 24 14 08 419
Fax: +420 24 14 08 439
E-mail: info@alto-cz.com

DENMARK

Nilfisk-Advance A/S
Industrivej 1
9560 Hadsund
Tel.: +45 7218 2100
Fax: +45 7218 2105
E-mail: salg@nilfisk-alto.dk
E-mail: service@nilfisk-alto.dk
www.nilfisk-alto.dk

Nilfisk-ALTO Food division
Division of Nilfisk-Advance A/S
Blytækervej 2
9000 Aalborg
Tel.: +45 7218 2100
Fax: +45 7218 2099
E-mail: scanio.technology@nilfisk-alto.dk

FINLAND

Nilfisk-Advance Oy Ab
Piispantilankuja 4
02240 Espoo
Tel.: +358 207 890 600
Fax: +358 207 890 601
E-mail: jukka.lehtonen@nilfisk-alto.com
www.nilfisk-advance.fi

FRANCE

Nilfisk-ALTO
ALTO France SAS

Aéroparc 1
19 rue Icare
67960 Entzheim
Tel.: +33 3 88 28 84 00
Fax: +33 3 88 30 05 00
E-mail: info@nilfisk-alto.fr
www.nilfisk-alto.com

GERMANY

Nilfisk-ALTO
Division of Nilfisk-Advance AG
Guido-Oberdorfer-Strasse 10
89287 Bellenberg
Tel.: +49 0180 5 37 37 37
Fax: +49 0180 5 37 37 38
E-mail: info@nilfisk-alto.de
www.nilfisk-alto.de

GREECE

Nilfisk-Advance SA
8, Thoukididou str.
164 52 Argiroupolis
Tel.: +30 210 96 33443
Fax: +30 210 96 52187
E-mail: nilfisk-advance@clean.gr

HOLLAND

Nilfisk-ALTO
Division of Nilfisk-Advance BV
Camerastraat 9
3322 BB Almere
Tel.: +31 36 546 07 60
Fax: +31 36 546 07 61
E-mail: info.nl@nilfisk-alto.nl
www.nilfisk-alto.nl

HONG KONG

Nilfisk-Advance Ltd.
2001 HK Worsted Mills Ind'l Bldg.
31-39 Wo Tong Tsui St.
Kwai Chung
Tel.: +852 2427 5951
Fax: +852 2487 5828

HUNGARY

Nilfisk-Advance Kereskedelmi Kft.
II. Rákóczi Ferenc út 10
2310 Szigetszentmiklos-Lakihegy
Tel.: +36 2447 5550
Fax: +36 2447 5551
E-mail: info@nilfisk-advance.hu
www.nilfisk-advance.hu

ITALY

Nilfisk-ALTO
Divisione di Nilfisk-Advance A/S
Località Novella Terza
26862 Guardamiglio (LO)
E-mail: d.puglia@nilfisk-advance.it

JAPAN

Nilfisk-Advance Inc.
1-6-6 Kita-shinyokohama, Kouhoku-ku
Yokohama, 223-0059
Tel.: +8145 548 2571
Fax: +8145 548 2541

MALAYSIA

Nilfisk-Advance Sdn Bhd
Sd 14, Jalan KIP 11
Taman Perindustrian KIP
Sri Damansara
52200 Kuala Lumpur
Tel.: +60 3 603 6275 3120
Fax: +60 3 603 6274 6318

MEXICO

Nilfisk-Advance de Mexico, S. de R.L. de C.V.
Prol. Paseo de la Reforma 61, 6-A2
Col. Paseo de las Lomas
01330 Mexico, D.F.
Tel.: +52 55 2591 1002 (switchboard)
Fax: +52 55 2591 1002 ext. 229
E-mail: info@advance-mx.com
www.nilfisk-advance.com.mx

NEW ZEALAND

Nilfisk-ALTO, Division of Nilfisk-Advance NZ
Private Bag 92829
6 Rockridge Avenue
Penrose, Auckland
Tel.: +64 9 525 0092
Fax: +64 9 525 6440

NORWAY

Nilfisk-Advance AS
Bjørnerudveien 24
1266 Oslo
Tel.: +47 22 75 17 70
Fax: +47 22 75 17 71
E-mail: info@nilfisk-alto.no
www.nilfisk-alto.no

POLAND

Nilfisk-Advance Sp. Z.O.O.
05-800 Pruszków
ul. 3-go MAJA 8

Tel.: +48 22 738 37 50
Fax: +48 22 738 37 51
E-mail: info@nilfisk-alto.pl
www.nilfisk-alto.pl

PORTUGAL

Nilfisk-ALTO
Division of Nilfisk-Advance Lda.
Sintra Business Park
Zona Industrial Da Abrunheira
Edificio 1, 1° A
P2710-089 Sintra
Tel.: +35 808 200 537
Fax: +35 121 911 2679
E-mail: mkt@nilfisk-advance.es

RUSSIA

Nilfisk-Advance LLC
Vyatskaya str. 27, bld. 7
127015 Moscow
Tel.: +7 495 783 96 02
Fax: +7 495 783 96 03
E-mail: info@nilfisk-advance.ru

SINGAPORE

Nilfisk-Advance Pte. Ltd.
Nilfisk-ALTO Division
40 Loyang Drive
Singapore 508961
Tel.: +65 6 759 9100
Fax: +65 6 759 9133
E-mail: sales@nilfisk-advance.com.sg

SPAIN

Nilfisk-ALTO
Division of Nilfisk-Advance S.A.
Torre D'Ar
Paseo del Rengle, 5 Pl. 10
08302 Mataró
Tel.: +3 4 902 200 201
Fax: +34 93 757 8020
E-mail: mkt@nilfisk-advance.es

SWEDEN

ALTO Sverige AB
Member of Nilfisk-Advance Group
Aminogatan 18, Box 4029
431 04 Mölndal
Tel.: +46 31 706 73 00
Fax: +46 31 706 73 40
E-mail: info@nilfisk-alto.se
www.nilfisk-alto.se

TAIWAN

Nilfisk-Advance Taiwan Branch
No. 5, Wan Fang Road
Taipei
Tel.: +886 227 002 268
Fax: +886 227 840 843

THAILAND

Nilfisk-Advance Co. Ltd.
89 Soi Chochechai-Ruammitr
Viphavadee-Rangsit Road
Ladyao, Jatuchak, Bangkok 10900
Tel.: +66 2 275 5630
Fax: +66 2 691 4079

TURKEY

Nilfisk-Advance Profesyonel Temizlik
Ekipmanlari Tic. A/S.
Necla Cad. No: 48
Yenisahra / Kadiköy
Istanbul
Tel.: +90 216 470 08 - 60
E-mail: info.tr@nilfisk-advance.com
www.nilfisk-advance.com.tr

UNITED KINGDOM

Nilfisk-ALTO
Division of Nilfisk-Advance Ltd.
Bowerbank Way
Gilwilly Industrial Estate, Penrith
Cumbria CA11 9BQ
Tel.: +44 1 768 86 89 95
Fax: +44 1 768 86 47 13
E-mail: sales@nilfisk-alto.co.uk
www.nilfisk-alto.co.uk

USA

Nilfisk-Advance Inc.
14600 21st Avenue North
Plymouth, MN 55447-3408
Tel.: +1 800 989 2235
Fax: +1 800 989 6566
E-mail: info@advance-us.com
www.advance-us.com

VIETNAM

Nilfisk-Advance Representative Office
No. 46 Doc Ngu Str.
Ba Dinh Dist.
Hanoi
Tel.: +84 4 761 5642
Fax: +84 4 761 5643
E-mail: nilfisk@vnn.vn